

DESCRIPTION	MATERIAL	FINISH
BODY	BRASS	NICKEL
SOCKET	Be Cu	GOLD
INSULATION	PTFE	N/A
WASHER	Ph BRONZE	GOLD
GASKET	Si RUBBER	RUBBER

REVISIONS			
REV	DESCRIPTION	DATE	APPV
B	REVISED FOOTPRINT DIMENSION	30-JUL-09	CJ
C	UPDATED FOOTPRINT AND DIMENSIONS; ADDED NEW TITLE BLOCK	10-JUL-12	SAH
D	UPDATED DRAWING AND DIMENSIONS	31-JUL-14	SAH
E	UPDATED DIMENSIONS, TITLE BLOCK AND NOTE 3	10-JUL-18	CLL

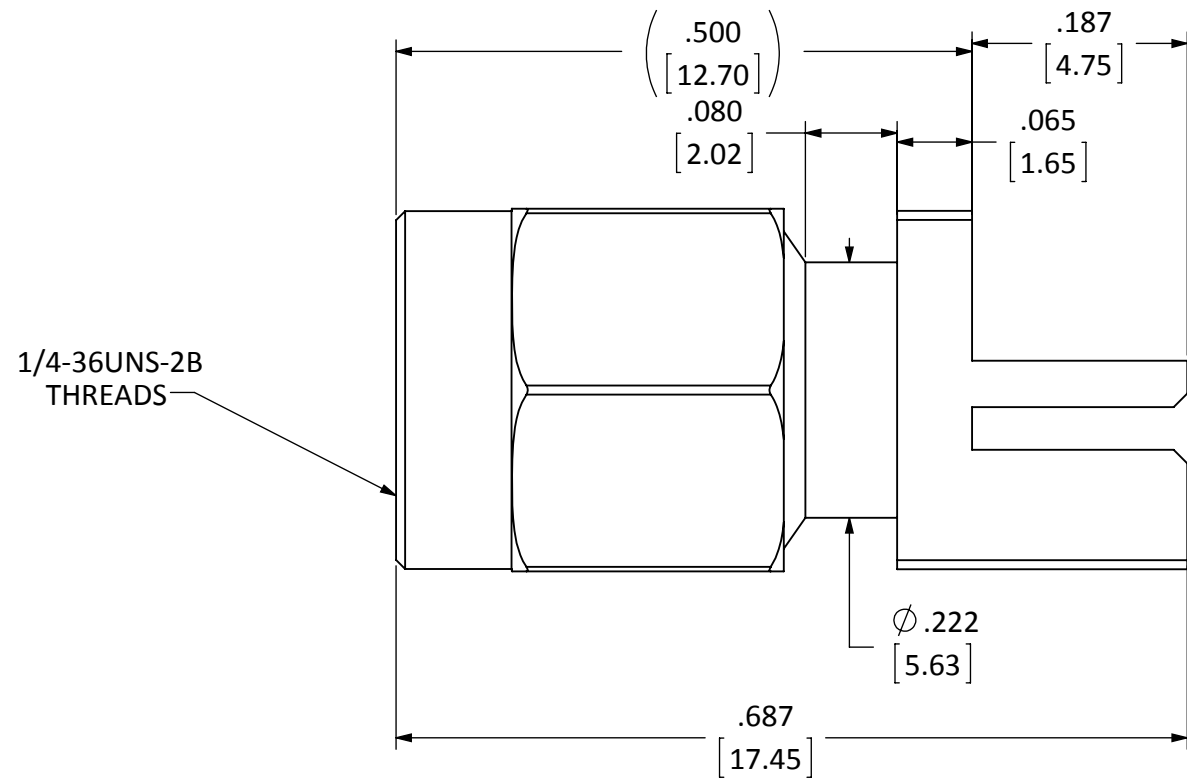

SIDE VIEW

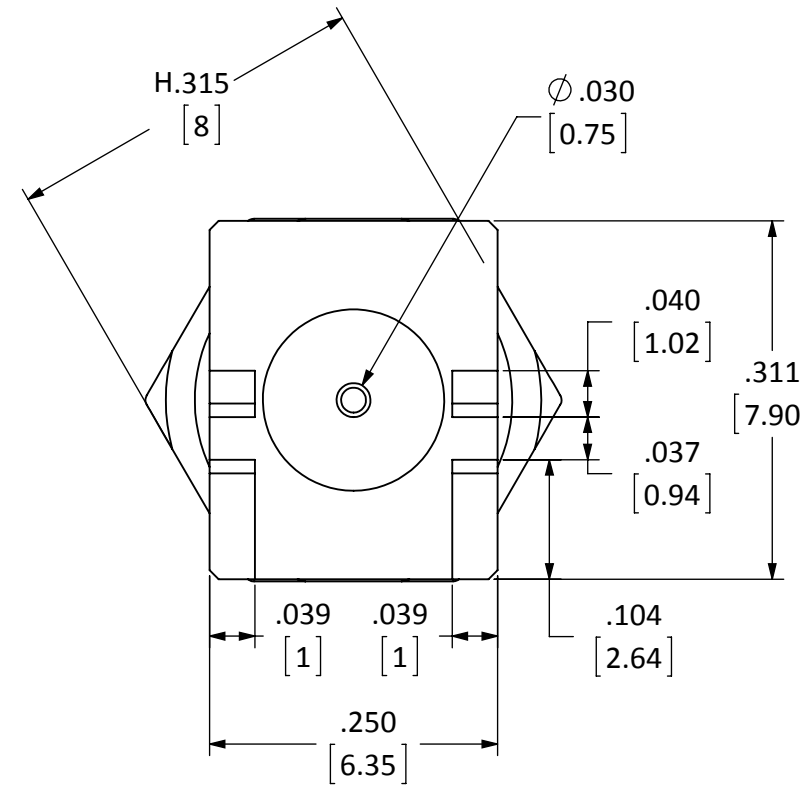

BACK VIEW

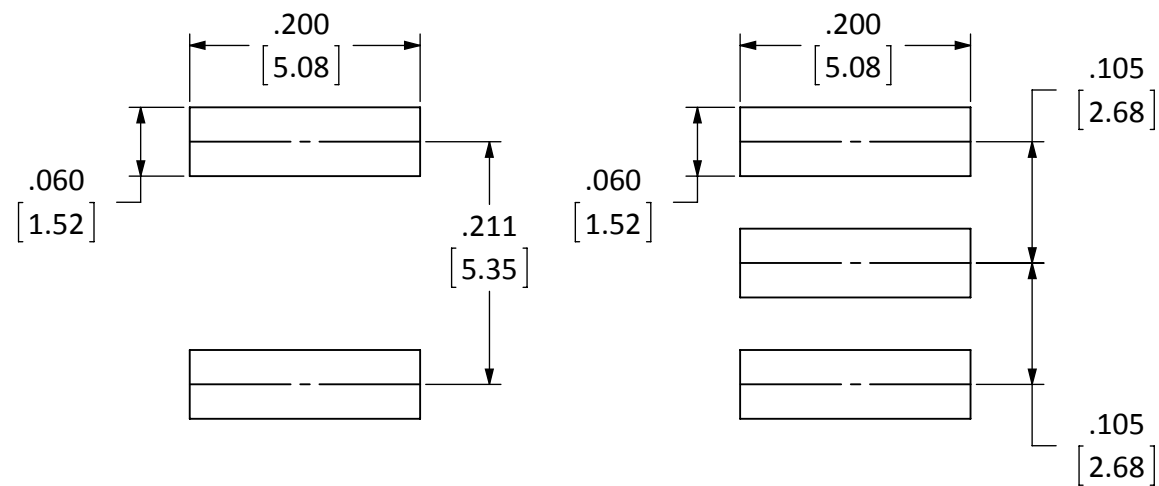

BOTTOM

TOP

RECOMMENDED FOOTPRINT

- NOTES: (UNLESS OTHERWISE SPECIFIED)
1. ALL DIMENSIONS ARE IN INCHES [mm].
 2. DIMENSIONS APPLY AFTER FINISHING.
 3. MANUFACTURE TO BE COMPLIANT WITH EU RoHS DIRECTIVE, USE MATERIALS THAT DO NOT CONTAIN REACH SUBSTANCES OF VERY HIGH CONCERN >1000ppm, AND USE DRC CONFLICT-FREE SOURCED MATERIALS.

WARNING: THIS DRAWING CONTAINS PROPRIETARY INFORMATION THAT IS THE SOLE PROPERTY OF LINX TECHNOLOGIES, AND SHALL BE TREATED AS SUCH. NO DISCLOSURE OR REPRODUCTION OF THIS DOCUMENT IS PERMITTED, IN WHOLE OR IN PART, WITHOUT THE EXPRESS WRITTEN PERMISSION OF LINX TECHNOLOGIES OR ITS DESIGNATED AGENTS.

Linx 159 ORT LANE
MERLIN, OR 97532

TITLE: **RP-SMA MALE EDGE MOUNT FOR 0.031" THICK BOARD**

MATERIAL:	TOLERANCES .020 [0.50]-.200 [5.00]= ±.008 [0.20] .200 [5.00]-1.200 [30.00]= ±.016 [0.40] 1.20 [30.0]-4.75 [120.0]= ±.024 [0.60] 4.75 [120.0]-12.40 [315.0]= ±.040 [1.0]	PROJECTION:
FINISH:	DRAWN: B.MURPHY DT: 2-JUL-14 ENGR: S.HOGAN DT: 31-JUL-14	ANGLES: ±1°

SIZE	DWG. NO.	REV
B	CONREVSMA013.031	E
SCALE: 6:1	DO NOT SCALE DRAWING	SHEET 1 OF 1