

Smart Power Stage (SPS) Module with Integrated High Accuracy Current and Temperature Monitors

ISL99227, ISL99227B

The [ISL99227](#), [ISL99227B](#) are Smart Power Stages (SPS) compatible with Intersil's ISL68xxx/69xxx Digital Multiphase (DMP) controllers and phase doubler (ISL6617A), respectively. The ISL99227, ISL99227B have integrated high accuracy current and temperature monitors that can be fed back to the controller and doubler to complete a multiphase DC/DC system. They simplify design and increase performance by eliminating the DCR sensing network and associated thermal compensation. Light-load efficiency is supported via a dedicated LFET control pin. An industry leading thermally enhanced 5x5 PQFN package allows minimal overall PCB real estate.

The ISL99227, ISL99227B feature a 3.3V compatible, 5.0V compatible tri-state PWM input that, working together with Intersil's multiphase PWM controllers, will provide a robust solution in the event of abnormal operating conditions. The ISL99227, ISL99227B also improve system performance and reliability with integrated fault protection of UVLO, over-temperature and overcurrent. An open-drain fault reporting pin simplifies the handshake between SPS and Intersil controllers and can be used to disable the controller during start-up and fault conditions.

Related Literature

- [TB363](#) "Guidelines for Handling and Processing Moisture Sensitive Surface Mount Devices (SMDs)"

Features

- Input range: +4.5V to +18V
- Supports 60A DC current
- ISL99227 with 3.3V compatible tri-state PWM input
- ISL99227B with 5.0V compatible tri-state PWM input
- Downslope current sensing
- ±3% accuracy current monitor (IMON) with REFIN input
- 8mV/°C temperature monitor with OT flag
- Dedicated low-side FET control input
- Comprehensive fault protection for high system reliability
 - High-side FET short and overcurrent protection
 - Over-temperature protection
 - V_{CC} and V_{IN} Undervoltage Lockout (UVLO)
- Open-drain fault reporting output
- Up to 2MHz switching frequency
- Pb-free (RoHS compliant), 32 Ld 5x5 PQFN

Applications

- High frequency and high efficiency VRM and VRD
- Core, graphic and memory regulators for microprocessors
- High density VR for server, networking and cloud computing
- POL DC/DC converters and video gaming consoles

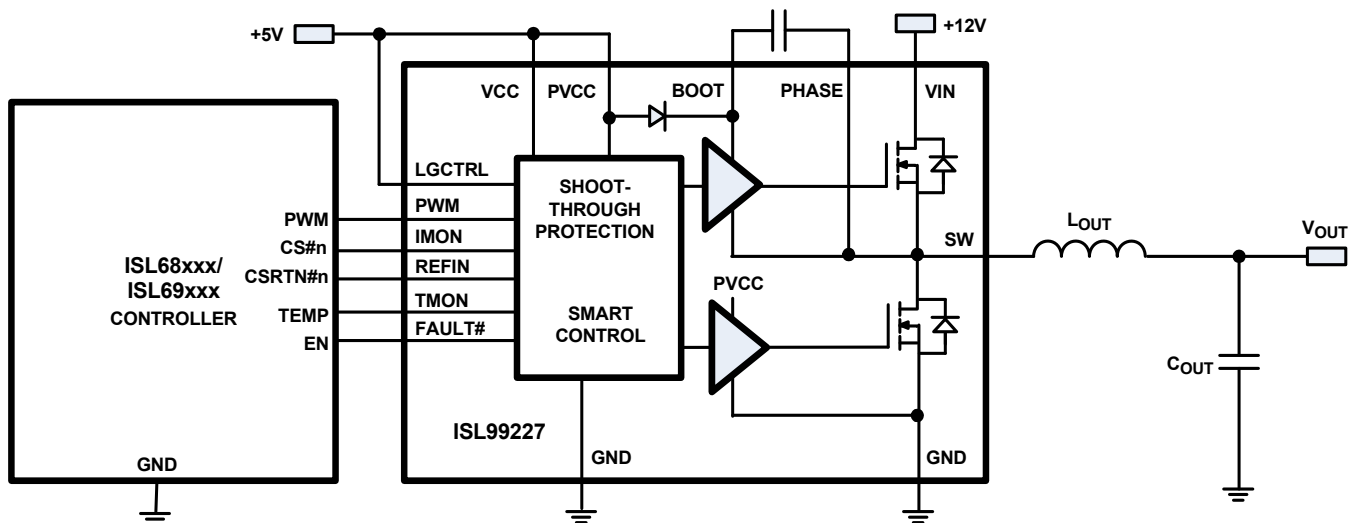

FIGURE 1. ISL99227 SIMPLIFIED APPLICATION BLOCK DIAGRAM

Typical Application Circuit with ISL99227B and ISL6617A

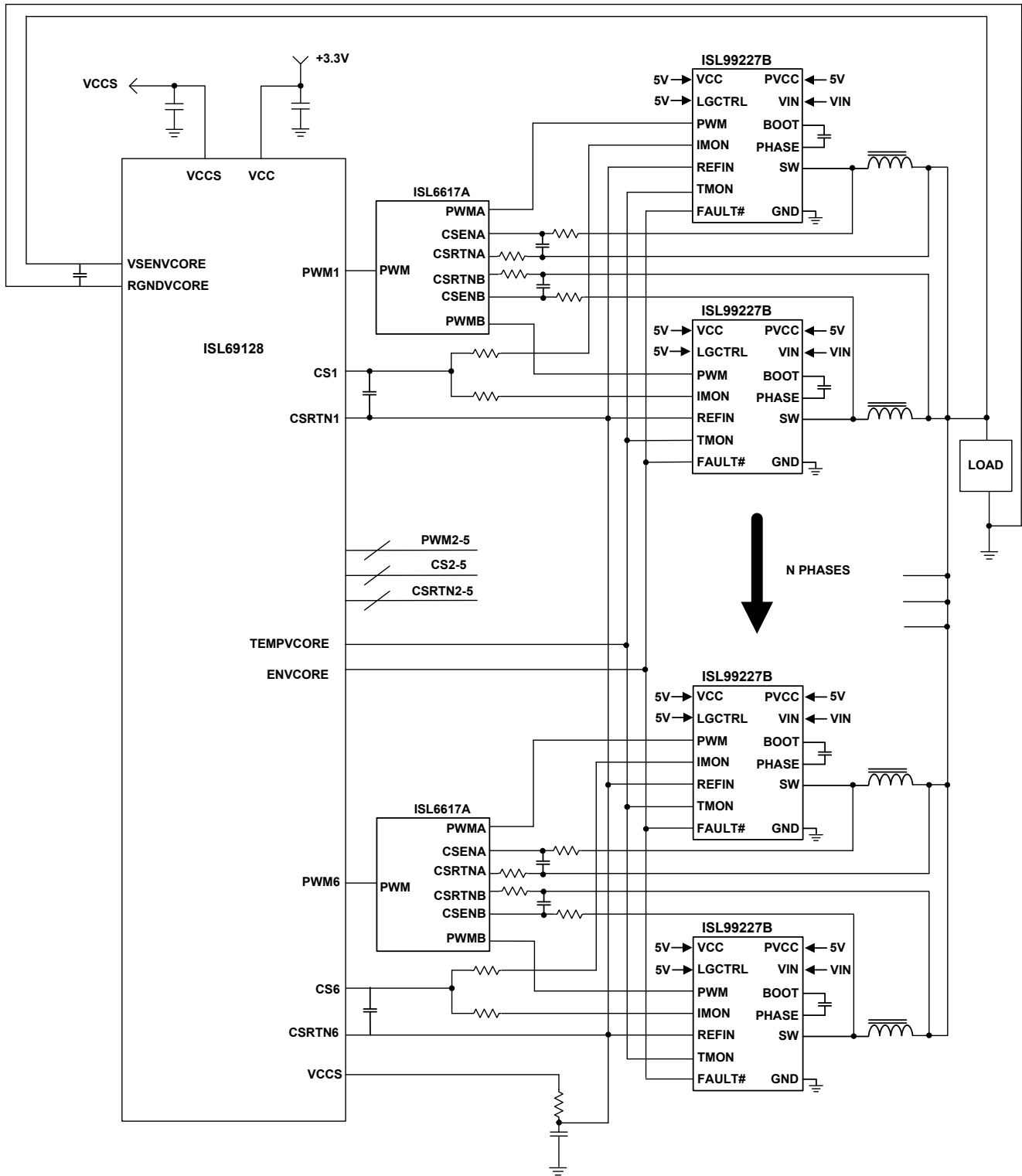

FIGURE 3. TYPICAL APPLICATION CIRCUIT WITH ISL99227B (COMPATIBLE WITH ISL6617A 5V PWM OUTPUT)

Functional Block Diagram

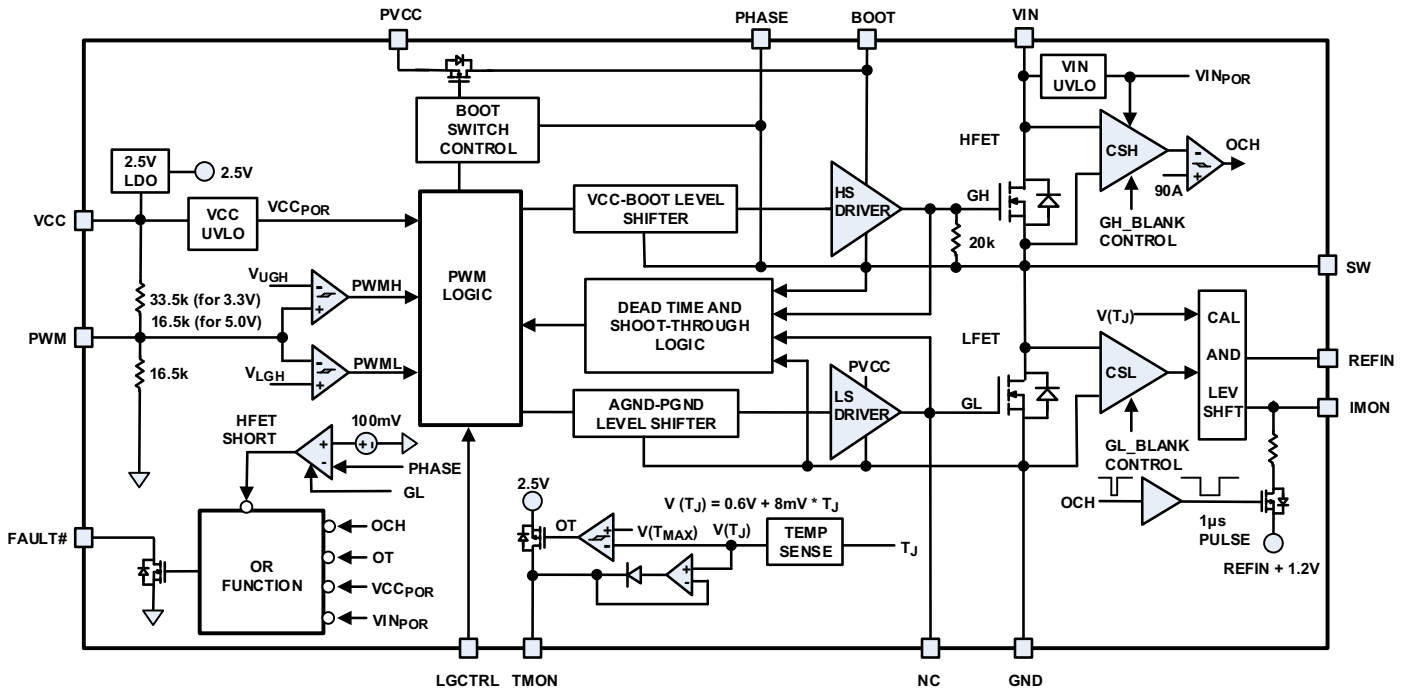

FIGURE 4. FUNCTIONAL BLOCK DIAGRAM

ISL99227, ISL99227B

Ordering Information

PART NUMBER (Notes 1, 2, 3)	PART MARKING	TEMP RANGE (°C)	CURRENT RATING	PWM INPUT (V)	TAPE AND REEL (UNITS)	PACKAGE (RoHS COMPLIANT)	PKG. DWG. #
ISL99227IRZ-T	27I	-40 to +85	60A	3.3	3k	32 Ld 5x5 PQFN Double Cooling	L32.5x5V
ISL99227HRZ-T	27H	-10 to +100	60A	3.3	3k	32 Ld 5x5 PQFN Double Cooling	L32.5x5V
ISL99227FRZ-T	27F	-40 to +125	60A	3.3	3k	32 Ld 5x5 PQFN Double Cooling	L32.5x5V
ISL99227BFRZ-T	27B	-40 to +125	60A	5.0	3k	32 Ld 5x5 PQFN Double Cooling	L32.5x5V

NOTES:

- Please refer to [TB347](#) for details on reel specifications.
- These Intersil plastic packaged products are RoHS compliant by EU exemption 7A and employ special Pb-free material sets, molding compounds/die attach materials, and 100% matte tin plate plus anneal (e3) termination finish which is compatible with both SnPb and Pb-free soldering operations. Intersil RoHS compliant products are MSL classified at Pb-free peak reflow temperatures that meet or exceed the Pb-free requirements of IPC/JEDEC J STD-020.
- For Moisture Sensitivity Level (MSL), please see product information page for [ISL99227](#), [ISL99227B](#). For more information on MSL, please see tech brief [TB363](#).

TABLE 1. KEY DIFFERENCES BETWEEN FAMILY OF PARTS

PART #	CURRENT RATING (A)	PWM (V)	THERMAL FLAG	OCP FLAG	IMON	TMON	PACKAGE	P2P COMPATIBLE	USED WITH
5.0V PWM POWER STAGE FAMILY									
ISL99125B	25	5.0	No	No	No	No	24 Ld 3.5x5 QFN	ISL99135B	Analog Controllers: ISL633x, ISL636x, ISL637x, ISL95829, ISL9585x Digital Hybrid Controllers: ISL68201, ISL6388/98 Full Digital Controller: ZL8802 Phase Doublers: ISL6617, ISL6617A (see Figure 3 on page 3)
ISL99135B	35	5.0	No	No	No	No	24 Ld 3.5x5 QFN	ISL99125B	
ISL99227B	60	5.0	Yes	Yes	Yes	Yes	32 Ld 5x5 PQFN	N/A	
3.3V PWM POWER STAGE FAMILY									
ISL99140	40	3.3	Yes	No	No	No	40 Ld 6x6 QFN	N/A	Full Digital Controllers: ISL68/69xxx (see Figure 2 on page 2), ZL8802 Digital Hybrid Controllers: ISL68201, ISL6388/98 (3.3V PWM Setting)
ISL99227	60	3.3	Yes	Yes	Yes	Yes	32 Ld 5x5 PQFN	N/A	

ISL99227, ISL99227B

Pin Configuration

ISL99227, ISL99227B
(32 LD PQFN)
TOP VIEW

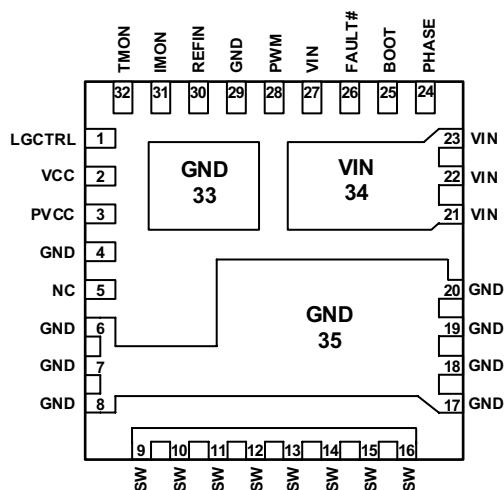

Pin Descriptions

PIN #	PIN NAME	DESCRIPTION
1	LGCTRL	Lower gate control signal input. LO = GL low (LFET off). HI = Normal operation (GL and GH strictly obey PWM). This pin should be driven with a logic signal, or externally tied high if not required; it should NOT be left floating.
2	VCC	+5V logic bias supply. Place a high quality low ESR ceramic capacitor (~1μF/X7R) in close proximity from this pin to GND.
3	PVCC	+5V gate drive bias supply. Place a high quality low ESR ceramic capacitor (~1μF/X7R) in close proximity from this pin to GND.
4, 6, 7, 8, 17, 18, 19, 20, 29, 33, 35	GND	All GND pins are internally connected. Pins 4 and 29 should be connected directly to the nearby GND paddles on package bottom. Figure 15 on page 14 shows GND paddles should be connected to the system GND plane with as many vias as possible to maximize thermal and electrical performance.
5	NC	No connect (this is a low-side gate driver output (GL), optional to monitor for system debugging).
9, 10, 11, 12, 13, 14, 15, 16	SW	Switching junction node between HFET source and LFET drain. Connect directly to output inductor.
21, 22, 23, 27, 34	VIN	Input of power stage (to drain of HFET). Place at least 2 ceramic capacitors (10μF or higher, X5R or X7R) in close proximity across VIN and GND. Pin 27 should NOT be used for decoupling. For optimal performance, place as many vias as possible in the bottom side VIN paddle.
24	PHASE	Return of boot capacitor. Internally connected to SW node so no external routing required for SW connection.
25	BOOT	Floating bootstrap supply pin for the upper gate drive. Place a high quality low ESR ceramic capacitor (0.1μF~0.22μF/X7R) in close proximity across BOOT and PHASE pins.
26	FAULT#	Open-drain output pin. Any fault (overcurrent, over-temperature, shorted HFET, or POR/UVLO) will pull this pin to ground. This pin may be connected to the controller Enable pin or used to signal a fault at the system level.
28	PWM	ISL99227: PWM input of gate driver, compatible with 3.3V tri-state PWM signal. ISL99227B for 5V PWM.
30	REFIN	Input for external reference voltage for IMON signal. This voltage should be between 0.8V and 1.6V. Connect REFIN to the appropriate current sense input of the controller. Place a high quality low ESR ceramic capacitor (~0.1μF) in close proximity from this pin to GND.
31	IMON	Current monitor output, referenced to REFIN. IMON will be pulled high (to REFIN + 1.2V) to indicate an HFET shorted or overcurrent fault. Connect the IMON output to the appropriate current sense input of the controller. No more than 56pF capacitance can be directly connected across IMON and REFIN pins. With a 100Ω series resistor, up to 470pF may be used.
32	TMON	Temperature monitor output. For multiphase, the TMON pins can be connected together as a common bus; the highest voltage (representing the highest temperature) will be sent to the PWM controller. TMON will be pulled high (to 2.5V) to indicate an over-temperature fault. No more than 470pF total capacitance can be directly connected across the TMON and GND pins; with a series resistor, a higher capacitance load is allowed, such as 1kΩ for 100nF load.

ISL99227, ISL99227B

Absolute Maximum Ratings

Supply Voltage (VCC, PVCC)	-0.3V to 6V
Input Supply Voltage (VIN)	-0.3V to 25V
PHASE, SW Voltage (V _{PH-GND} , V _{SW-GND})	-0.3V to 25V GND - 10V (<20ns Pulse Width, 10μJ)
BOOT Voltage (V _{BOOT-GND})	-0.3V to 36V
Other I/O Pin Voltage	-0.3V to VCC + 0.3V
ESD Ratings	
Human Body Model (Tested per JEDEC-JS-001-2014)	2.5kV
Charged Device Model (Tested per JS-002-2014)	1kV
Machine Model (Tested per JESD22-A115C)	250V
Latch-Up (Tested per JESD-78E; Class 2, Level A)	100mA

Thermal Information

Thermal Resistance	θ_{JA} (°C/W)	θ_{JC} (°C/W)
32 Ld 5x5 PQFN		
Double Cooling Package (Notes 4, 5, 7)	10.7	4
Maximum Junction Temperature (Plastic Package)	+150°C	
Maximum Storage Temperature Range	-65°C to +150°C	
Pb-Free Reflow Profile	see TB493	

Recommended Operating Conditions

Operating Junction Temperature Range	
IRZ	-40°C to +85°C
HRZ	-10°C to +100°C
FRZ	-40°C to +125°C
Supply Voltage, VCC, PVCC	5V ±5%
Input Supply Voltage, VIN	4.5V to 18V

CAUTION: Do not operate at or near the maximum ratings listed for extended periods of time. Exposure to such conditions may adversely impact product reliability and result in failures not covered by warranty.

NOTES:

- θ_{JA} is measured in free air with the component mounted on an Intersil SPS evaluation board. Refer to Tech Brief [TB379](#) for general thermal metric info.
- For θ_{JC} , the “case temp” location is the center of the package underside.

Electrical Specifications

Recommended operating conditions, unless otherwise noted. **Boldface limits apply across the operating temperature range, T_J = -40°C to +125°C.**

PARAMETER	SYMBOL	TEST CONDITIONS	MIN (Note 6)	TYP	MAX (Note 6)	UNIT
POWER RATING						
Maximum Instant Power Dissipation		T _A = +25°C, 150A, (Note 7)		100		W
Maximum Continuous Power Dissipation		T _A = +25°C, θ_{JA} = 10°C/W, T _J = +150°C, (Note 7)		12.5		W
THERMAL RESISTANCE						
Thermal Resistance Junction to PCB	θ_{JB}	Intersil SPS evaluation board, (Note 7)		5.2		°C/W
Thermal Resistance Junction to Ambient	θ_{JA}	Intersil SPS evaluation board, (Note 7), 0 LFM		10.7		°C/W
Thermal Resistance Junction to Ambient	θ_{JA}	Intersil SPS evaluation board, (Note 7), 400 LFM		9.3		°C/W
VCC SUPPLY CURRENT						
Logic Standby Current	IVCC	PWM = Open		4.75		mA
Gate Drive Standby Current	IPVCC	PWM = Open		100		μA
Logic Operational Current	IVCC	PWM = 300kHz		4.75		mA
Gate Drive Operational Current	IPVCC	PWM = 300kHz		15		mA
POWER-ON RESET AND ENABLE						
VCC Rising POR Threshold				3.86	4.20	V
VCC Falling POR Threshold			3.20	3.58		V
VCC POR Hysteresis				280		mV
VCC POR Delay to Operation				125	197	μs
VIN Rising POR Threshold				4.0	4.2	V
VIN Falling POR Threshold			3.4	3.5		V
VIN POR Hysteresis				445		mV
3.3V PWM INPUT FOR ISL99227 (See “TIMING DIAGRAM” Figure 5 on page 9)						
Sink Impedance				33.5		kΩ
Source Impedance				16.5		kΩ

ISL99227, ISL99227B

Electrical Specifications Recommended operating conditions, unless otherwise noted. **Boldface limits apply across the operating temperature range, $T_J = -40^\circ\text{C}$ to $+125^\circ\text{C}$.** (Continued)

PARAMETER	SYMBOL	TEST CONDITIONS	MIN (Note 6)	TYP	MAX (Note 6)	UNIT
Tri-State Lower Gate Falling Threshold		$V_{CC} = 5V$		1.11		V
Tri-State Lower Gate Rising Threshold		$V_{CC} = 5V$		0.87		V
Tri-State Upper Gate Rising Threshold		$V_{CC} = 5V$		2.13		V
Tri-State Upper Gate Falling Threshold		$V_{CC} = 5V$		1.95		V
Tri-State Shutdown Window		$V_{CC} = 5V$	1.3		1.8	V
5V PWM INPUT FOR ISL99227B (See "TIMING DIAGRAM" on Figure 5 on page 9)						
Sink Impedance				16.5		k Ω
Source Impedance				16.5		k Ω
Tri-State Lower Gate Falling Threshold		$V_{CC} = 5V$		1.51		V
Tri-State Lower Gate Rising Threshold		$V_{CC} = 5V$		1.14		V
Tri-State Upper Gate Rising Threshold		$V_{CC} = 5V$		3.24		V
Tri-State Upper Gate Falling Threshold		$V_{CC} = 5V$		3.02		V
Tri-State Shutdown Window		$V_{CC} = 5V$	1.6		2.8	V
SWITCHING TIME						
GH Turn-On Propagation Delay	t_{PDHU}	See Figure 5 (GL Low to GH High)		8		ns
GH Turn-Off Propagation Delay	t_{PDLU}	See Figure 5 (PWM Low to GH Low)		40		ns
GL Turn-On Propagation Delay	t_{PDHL}	See Figure 5 (GH Low to GL High)		8		ns
GL Turn-Off Propagation Delay	t_{PDLL}	See Figure 5 (PWM High to GL Low)		23		ns
GL Exit Tri-State Propagation Delay	t_{PDTSL}	See Figure 5 (Tri-state to GL High)		25		ns
GH Exit Tri-State Propagation Delay	t_{PDTSU}	See Figure 5 (Tri-state to GH High)		35		ns
PWML to Tri-State Shutdown Hold-Off Time	t_{TSSHDL}	See Figure 5 (PWM Low to GL Low)		40		ns
PWMH to Tri-State Shutdown Hold-Off Time	$t_{TSSH DU}$	See Figure 5 (PWM High to GH Low)		50		ns
CURRENT MONITOR						
REFIN Voltage Range			0.8	1.2	1.6	V
IMON Current Gain Accuracy (Intersil SPS Validation Board, $V_{CC} = 5V$)		10A, $T_J = +90^\circ\text{C}$		± 2		%
		$\geq 10A$, $T_J = +40^\circ\text{C}$ to $+125^\circ\text{C}$		± 3		%
		$\geq 10A$, $T_J = +20^\circ\text{C}$ to $+125^\circ\text{C}$		± 4		%
Downslope Blanking Time				160		ns
HFET Overcurrent Trip		$V_{CC} = 5V$		90		A
IMON-REFIN at OCP			1.1	1.2	1.3	V
TEMPERATURE MONITOR						
Over-Temperature Rising Threshold				140		$^\circ\text{C}$
Over-Temperature Falling Threshold				125		$^\circ\text{C}$
Over-Temperature Hysteresis				15		$^\circ\text{C}$
Temperature Coefficient				8		mV/K
TMON Voltage at $+25^\circ\text{C}$ Temperature		$V(T_J) = 0.6V + (8\text{mV} \cdot T_J)$		0.80		V
TMON High at Over-Temperature			2.3	2.5	2.7	V
FAULT PIN						
Output Low Voltage		5mA		0.18	0.26	V
Leakage Current				16		nA

ISL99227, ISL99227B

Electrical Specifications Recommended operating conditions, unless otherwise noted. **Boldface limits apply across the operating temperature range, $T_j = -40^\circ\text{C}$ to $+125^\circ\text{C}$.** (Continued)

PARAMETER	SYMBOL	TEST CONDITIONS	MIN (Note 6)	TYP	MAX (Note 6)	UNIT
BOOTSTRAP DIODE						
Forward Voltage Drop		5mA		0.09		V
ON-Resistance	R_F			16		Ω
LGCTRL PIN						
Rising Threshold		Logic high; (normal: obeys PWM)		1.29	1.60	V
Falling Threshold		Logic low; (forces GL low; LFET off)	0.70	1.01		V
MOSFETs						
High-Side MOSFET (HFET) $r_{DS(ON)}$				3.84		m Ω
Low-Side MOSFET (LFET) $r_{DS(ON)}$				0.76		m Ω

NOTES:

- Compliance to datasheet limits is assured by one or more methods: production test, characterization and/or design.
- These ratings vary with PCB layout and operating condition, and limited by SPS temperature and thermal shutdown trip point.

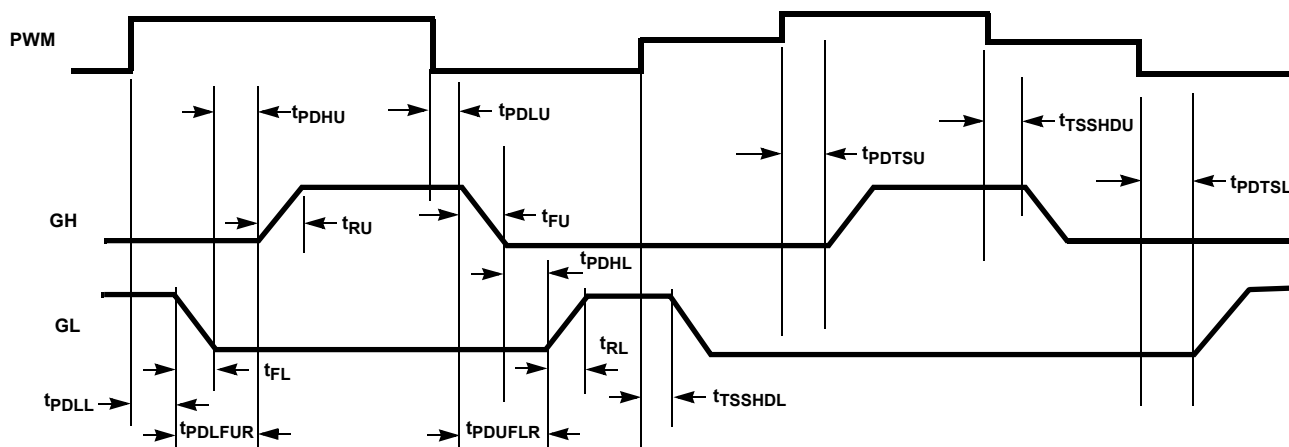

FIGURE 5. TIMING DIAGRAM (INTERNAL SIGNALS)

Typical Performance Characteristics

$V_{CC} = 5V$, $T_A = +25^\circ C$, unless otherwise stated.

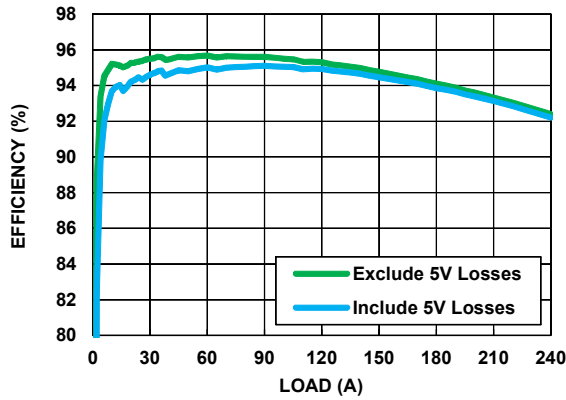

FIGURE 6. 1.8V V_{OUT} POWER STAGE EFFICIENCY ($V_{IN} = 12V$; $f_{SW} = 500kHz$; $L_{OUT} = 0.18\mu H/0.17m\Omega/FP1008-180-R$; AUTO-PHASE ENABLED IN 6-PHASE OPERATION)

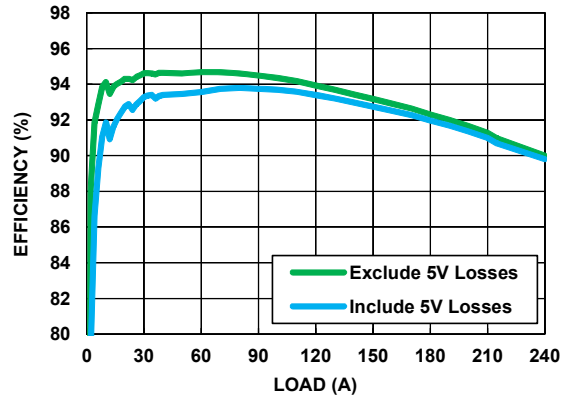

FIGURE 7. 1.2V V_{OUT} POWER STAGE EFFICIENCY ($V_{IN} = 12V$; $f_{SW} = 500kHz$; $L_{OUT} = 0.18\mu H/0.17m\Omega/FP1008-180-R$; AUTO-PHASE ENABLED IN 6-PHASE OPERATION)

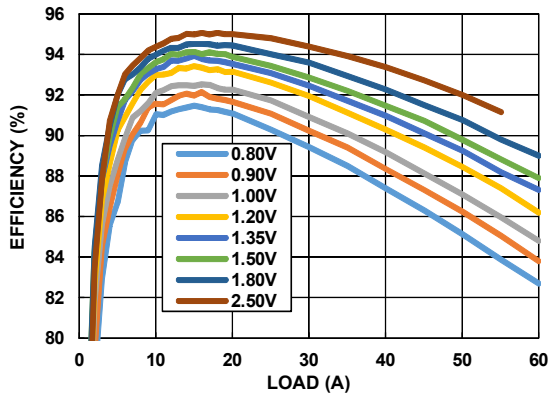

FIGURE 8. POWER STAGE EFFICIENCY ($V_{IN} = 12V$; $f_{SW} = 500kHz$; $L_{OUT} = 0.18\mu H/0.17m\Omega/FP1008-180-R$; INCLUDE INDUCTOR AND ISL99227, ISL99227B LOSSES)

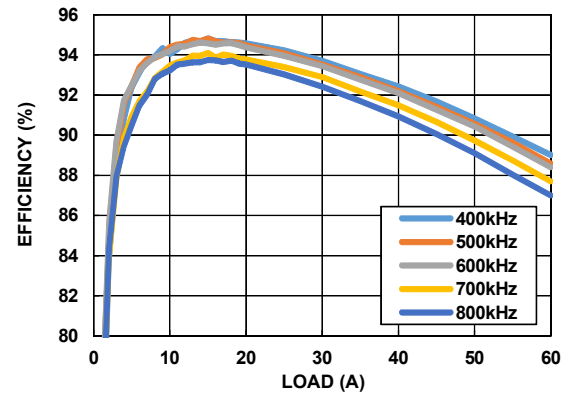

FIGURE 9. POWER STAGE EFFICIENCY ($V_{IN} = 12V$; $V_{OUT} = 1.8V$; $L_{OUT} = 0.18\mu H/0.17m\Omega/FP1008-180-R$; INCLUDE INDUCTOR AND ISL99227, ISL99227B LOSSES)

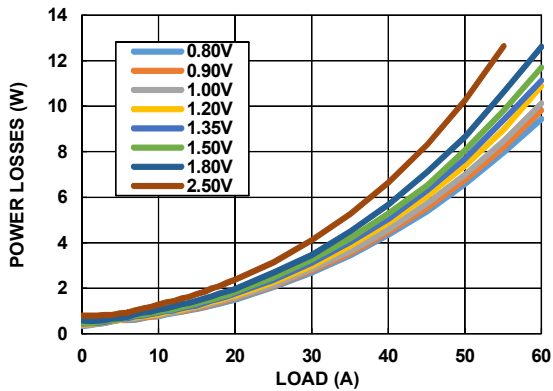

FIGURE 10. ISL99227, ISL99227B POWER DISSIPATION ($V_{IN} = 12V$; $f_{SW} = 500kHz$; $L_{OUT} = 0.18\mu H/0.17m\Omega/FP1008-180-R$)

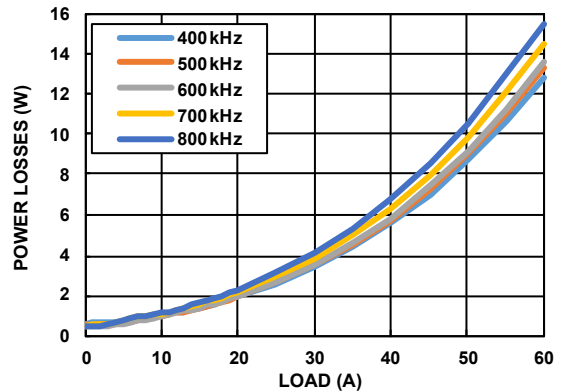

FIGURE 11. ISL99227, ISL99227B POWER DISSIPATION ($V_{IN} = 12V$; $V_{OUT} = 1.8V$; $L_{OUT} = 0.18\mu H/0.17m\Omega/FP1008-180-R$)

Operation

The ISL99227, ISL99227B are optimized drivers and power stage solutions for high density synchronous DC/DC power conversion. They include high performance GH and GL drivers, an NFET controlled to function as a bootstrap diode and MOSFET pair optimized for high switching frequency buck voltage regulators. They also include advanced power management features listed as follows:

1. Accurate current and thermal reporting outputs.
2. Fault protections of HFET overcurrent, HFET short, over-temperature, VCC UVLO and VIN UVLO.

Power-On Reset (POR)

During initial start-up, the V_{CC} voltage rise is monitored. Once the rising V_{CC} voltage exceeds 3.86V (typical) for 125 μ s, then normal operation of the driver is enabled. The PWM signals are passed through to the gate drivers, the TMON output is valid and the IMON-REFIN output starts at zero, and becomes valid on the first GL signal. If V_{CC} drops below the falling threshold of 3.58V (typical), operation of the driver is disabled. The PVCC voltage is not monitored as it should to be from the same supply as V_{CC} .

V_{IN} POR is also monitored. When both V_{CC} and V_{IN} reach above their POR trip points, it enables HFET overcurrent protection.

Both V_{CC} and V_{IN} POR are gated to the FAULT# pin, which goes high once both V_{CC} and V_{IN} are above their POR levels after 125 μ s and no other faults occur.

Shoot-Through Protection

Prior to POR, the undervoltage protection function is activated and both GH and GL are held active low (HFET and LFET off). After POR (the Rising Thresholds; see "Electrical Specifications" on page 8) and a 125 μ s delay, the PWM and LGCTRL signals are used to control both high-side and low-side MOSFETs, as shown in Table 2.

The ISL99227, ISL99227B's dead time control is optimized for high efficiency and guarantees that simultaneous conduction of both FETs cannot occur.

Should the driver have no bias voltage applied (either V_{CC} or PVCC missing) and be unable to actively hold the MOSFETs off, an integrated 20k Ω resistor from the upper MOSFET gate-to-source will aid in keeping the HFET device in its off state. This can be especially critical in applications where the input voltage rises prior to the ISL99227, ISL99227B V_{CC} and PVCC supplies.

TABLE 2. GH AND GL OPERATION TRUTH TABLE

PWM	LGCTRL	GH	GL	HFET, LFET	COMMENT
3-state	X	0	0	Both off	
0	1	0	1	LFET on	Normal
1	1	1	0	HFET on	Normal
0	0	0	0	LFET off	GL low
1	0	1	0	HFET on	Normal

Tri-State PWM Input

The ISL99227 supports a 3.3V PWM tri-level input and is compatible with Intersil's digital multiphase controllers as well as other control IC's utilizing 3.3V PWM logic. Use the ISL99227B for 5V PWM logic, like ISL6617A doubler with 5V PWM logic output (see Table 1 on page 5). Should the pin be pulled into and remain in the tri-state window for a set hold-off time, the driver will force both MOSFETs to their off states. When the PWM signal moves outside the shutdown window, the driver immediately resumes driving the MOSFETs according to the PWM commands.

This feature is utilized by Intersil's PWM controllers as a method of forcing both MOSFETs off. Should the PWM input be left floating, the pin will be pulled into the tri-state window internally and thus force both MOSFETs to a safe off state.

Although the PWM input can sustain a voltage as high as V_{CC} , the ISL99227 is not compatible with a controller (such as the ISL63xx family) that actively drives its mid-level in tri-state higher than 1.7V.

Bootstrap Function

The ISL99227, ISL99227B feature an internal NFET that is controlled to function as a bootstrap diode. A high quality ceramic capacitor should be placed in close proximity across the BOOT and PHASE pins. The bootstrap capacitor can range between 0.1 μ F~0.22 μ F (0402~0603 and X5R~X7R) for normal buck switching applications.

Current Monitoring

LFET current is monitored and a signal proportional to that current is the output on the IMON pin (relative to the REFIN pin). The IMON and REFIN pins should be connected to the appropriate current sense input pin of the controller. This method does not require external R_{SENSE} or DCR sensing of the inductor current.

Figure 12 depicts the low-side current sense concept. After the falling edge of the PWM, there are two delays; one that represents the expected propagation delay from PWM to GH/SW and a second blanking delay to allow time for the transition to settle; typical total time is ~350ns. The IMON output approximates the actual I_L waveform.

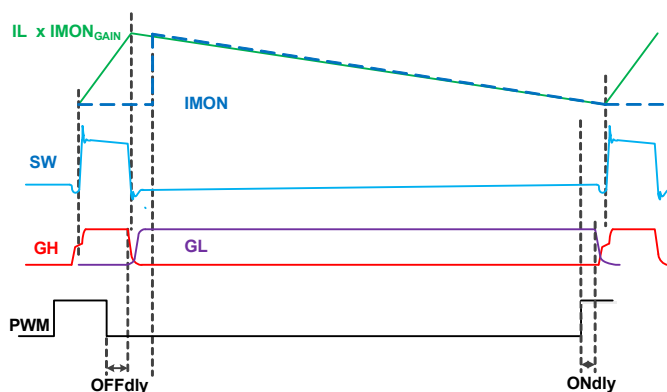

FIGURE 12. LFET CURRENT SAMPLE DIAGRAM

ISL99227, ISL99227B

The HFET current is NOT monitored in the same way, so no valid measured current is available while PWM is high (including the short delays before and after). During this time, the IMON will output the last valid LFET current before the sampling stopped. On start-up after POR, the IMON will output zero (relative to REF_{IN}, which represents zero current) until the switching begins and then the current can be properly measured.

The high-side FET current is separately monitored for OC conditions; see the following [“Overcurrent Protection”](#) section.

Overcurrent Protection

[Figure 13](#) shows the timing diagram of an overcurrent fault. There is a comparator monitoring the HFET current while it is on (GH high; also requires V_{IN} POR above its trip point). If the current is higher than 90A (typical; not user-programmable), then an OC fault is detected. The GH will be forced low, even if PWM is still high; this effectively shortens the PWM (and GH) pulse width, to limit the current. The IMON pin is pulled up to $REF_{IN} + 1.2V$, which will be detected by the controller as an overcurrent fault. The controller is then expected to force PWM to tri-state (gates off both FETs), which signals the SPS that the fault has been acknowledged. The fault clears $\sim 1\mu s$ after PWM enters tri-state. The IMON flag is released after the delay. The driver will then normally respond to the PWM inputs. If the PWM tri-state signal is not received after the fault, then the fault stays asserted and the IMON pin remains high.

Note that if the controller does NOT acknowledge, the IMON flag will stay high indefinitely, which will also hold GH low.

If OC is detected, the FAULT# pin is also pulled low; the timing on the FAULT# pin will follow that of the IMON pin.

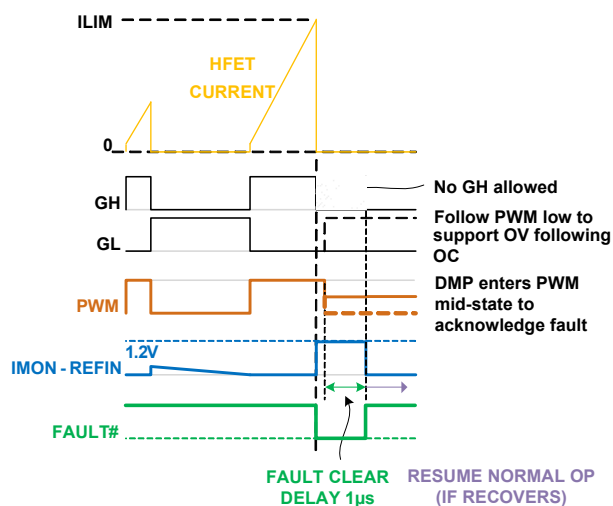

FIGURE 13. OVERCURRENT FAULT TIMING DIAGRAM

Shorted HFET Protection

In case of a shorted HFET, the SW node will have excessive positive voltage present even when the LFET is turned on. The ISL99227, ISL99227B monitor the SW node during periods when the LFET is on (GL is high) and should that voltage exceed 100mV (typical), the HFET short fault is declared. The ISL99227, ISL99227B will pull the IMON pin high and the FAULT# will be pulled low. However, the fault will be latched; VCC POR is needed to reset it. GH will be gated low (ignore PWM = high), thus the ISL99227, ISL99227B will still respond to PWM tri-state and logic low.

Thermal Monitoring

The ISL99227, ISL99227B monitor their internal temperature and provides a signal proportional to that temperature on the TMON pin. TMON has a voltage of 600mV at 0°C and reflects temperature at 8mV/°C. The TMON output is valid 125µs after VCC POR.

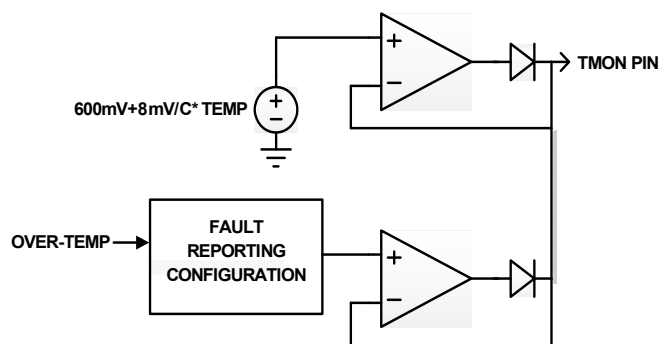

FIGURE 14. OVER-TEMPERATURE FAULT

[Figure 14](#) shows a simplified functional representation. The top section includes the sensor and the output buffer. The bottom section includes the protection sensing that will pull the output high. The TMON pin is configured internally such that a user can tie multiple pins together externally and the resulting TMON bus will assume the voltage of the highest contributor (representing the highest temperature).

Thermal Protection

Should the internal temperature exceed the over-temperature trip point (+140°C typical), the TMON pin will be pulled high (to $\sim 2.5V$), and the FAULT# pin will be pulled low. No other action is taken on-chip. Both the TMON and FAULT# pins will remain in the fault mode until the junction temperature drops below +125°C (typical); at that point, the TMON and FAULT# pins resume normal operation.

FAULT Reporting

Overcurrent and shorted HFET detections will pull the IMON pin to a high (fault) level, such that the PWM controller should quickly recognize it as out of the normal range. Over-temperature detection will pull the TMON pin to a high (fault) level, such that the PWM controller should quickly recognize it as out of the normal range.

All of the above faults, plus the VCC and VIN POR (UVLO) conditions, will also pull down the FAULT# pin. This can be used by the controller (or system) as a fault detection and can also be used to disable the controller through its Enable pin.

The fault reporting and respective SPS response are summarized in [Table 3](#).

TABLE 3. FAULT REPORTING SUMMARY

FAULT EVENT	IMON	TMON	FAULT#	RESPONSE
OC	HIGH	N/A	LOW	GH gated off. The controller should acknowledge and force its PWM to tri-state to keep both HFET and LFET off. The fault is cleared ~1 μ s after PWM enters tri-state, otherwise, it stays asserted. (If system OVP occurs, the controller may send PWM low to turn on LFET).
Shorted HFET	IMON Latched HIGH	N/A	FAULT# Latched LOW	GH gated off, until fault latch is cleared by VCC POR. GL follows PWM.
OT	N/A	HIGH	LOW	GH and GL follow PWM.
VCC UVLO	IMON-REFIN = OV	TMON Not Valid	LOW	Switching stops while in UVLO. Once above VCC POR, after 125 μ s: GH and GL follow PWM; the FAULT# pin is released; TMON is valid; IMON-REFIN is valid after GL first goes low.
VIN UVLO	OC not valid	N/A	LOW	GH and GL follow PWM.

PCB Layout Considerations

Proper PCB layout will reduce noise coupling to other circuits, improve thermal performance and maximize the efficiency. The following is meant to lead to an optimized layout:

- Place multiple 10 μ F or greater ceramic capacitors directly on the device between VIN and GND as indicated in [Figure 15 on page 14](#). This is the most critical decoupling and reduced parasitic inductance in the power switching loop. This will reduce overall electrical stress on the device as well as reduce coupling to other circuits. Best practice is to place the decoupling capacitors on the same PCB side as the device. For a design with tight space requirements, these decoupling capacitors can be placed under the device, i.e., bottom layer, as shown in [Figure 17 on page 15](#).
- Connect GND to the system GND plane with a large via array as close to the GND pins as design rules allow. This improves thermal and electrical performance.
- Place PVCC, VCC and BOOT-PHASE decoupling capacitors at the IC pins as shown in [Figure 15 on page 14](#).
- Note that the SW plane connecting the ISL99227, ISL99227B and inductor must carry full load current and will create resistive loss if not sized properly. However, it is also a very noisy node that should not be oversized or routed close to any sensitive signals. Best practice is to place the inductor as close to the device as possible and thus minimizing the required area for the SW connection. If one must choose a long route of either the VOUT side of the inductor or the SW side, choose the quiet VOUT side. Best practice is to locate the ISL99227, ISL99227B as close to the final load as possible and thus avoid noisy or lossy routes to the load.
- The IMON and IREF network and their vias should not sit on the top of the VIN plane, a keep out area is recommended, as shown in [Figure 17 on page 15](#).
- The PCB is the best thermal heatsink material than any top side cooling materials. The PCB always has enough vias to connect VIN and GND planes. Insufficient vias will yield lower efficiency and very poor thermal performance.

[Figures 16](#) and [17](#) show a multiphase PCB layout example for dual footprint, a device compatible with ISL99227. For a reference design file, please contact Intersil's Application support at www.intersil.com/en/support.html.

ISL99227, ISL99227B

TABLE 4. AVAILABLE EVALUATION BOARDS

EVALUATION BOARDS	PEAK EFFICIENCY (%)	SMBus/ PMBus/ I^2C	DESCRIPTION
ISL69127-61P-EV1Z	95.7% at 60A	Yes	6+1 Dual Output VR13 Evaluation Board for V_{CORE} and VSA Applications
ISL69125-31P-EV2Z	94.5% at 30A	Yes	3+1 Dual Outputs DDR4 Evaluation Board for VR13 Memory Applications

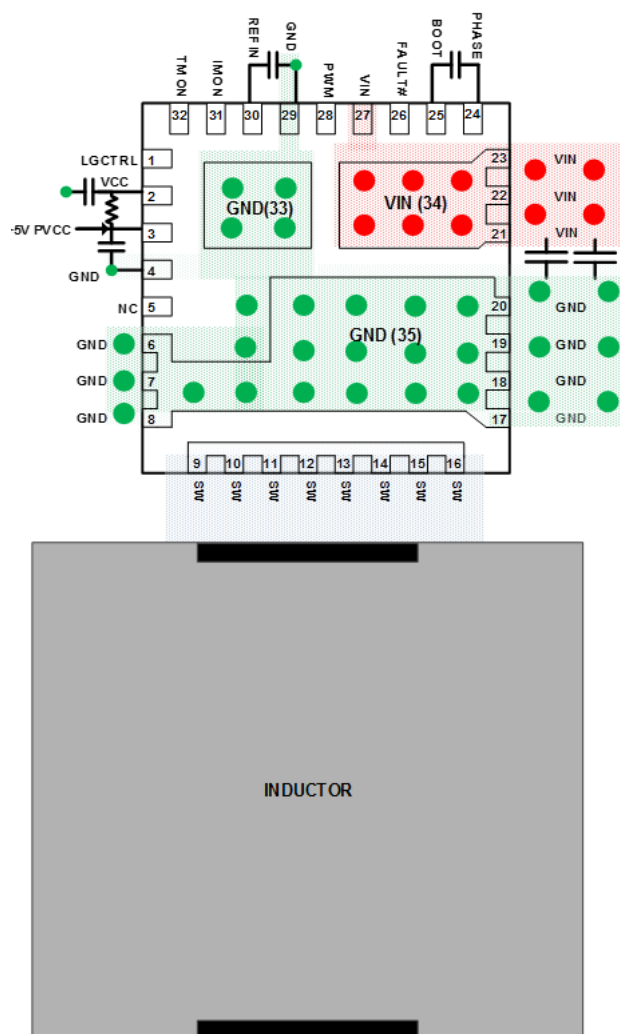

FIGURE 15. SINGLE-PHASE PCB LAYOUT FOR MINIMIZING CURRENT LOOPS

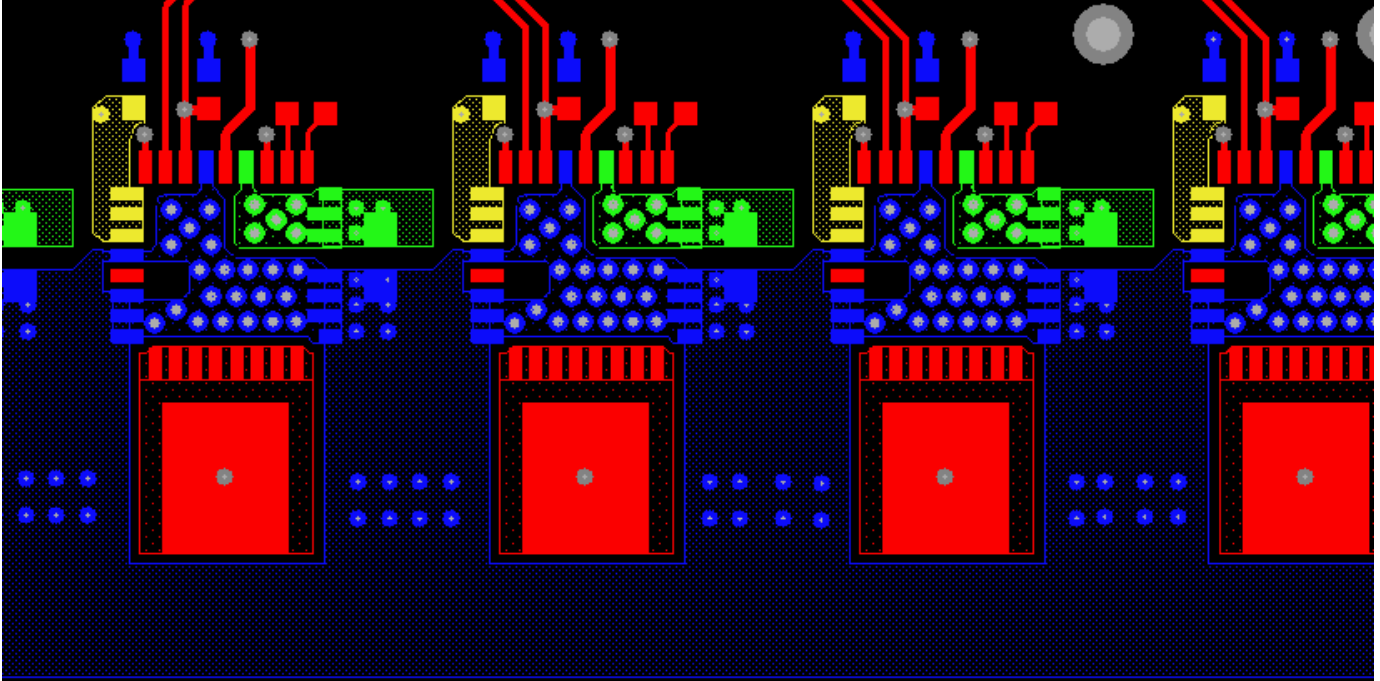

FIGURE 16. MULTIPHASE PCB LAYOUT EXAMPLE TOP LAYER FOR DUAL FOOTPRINT, A DEVICE COMPATIBLE WITH ISL99227

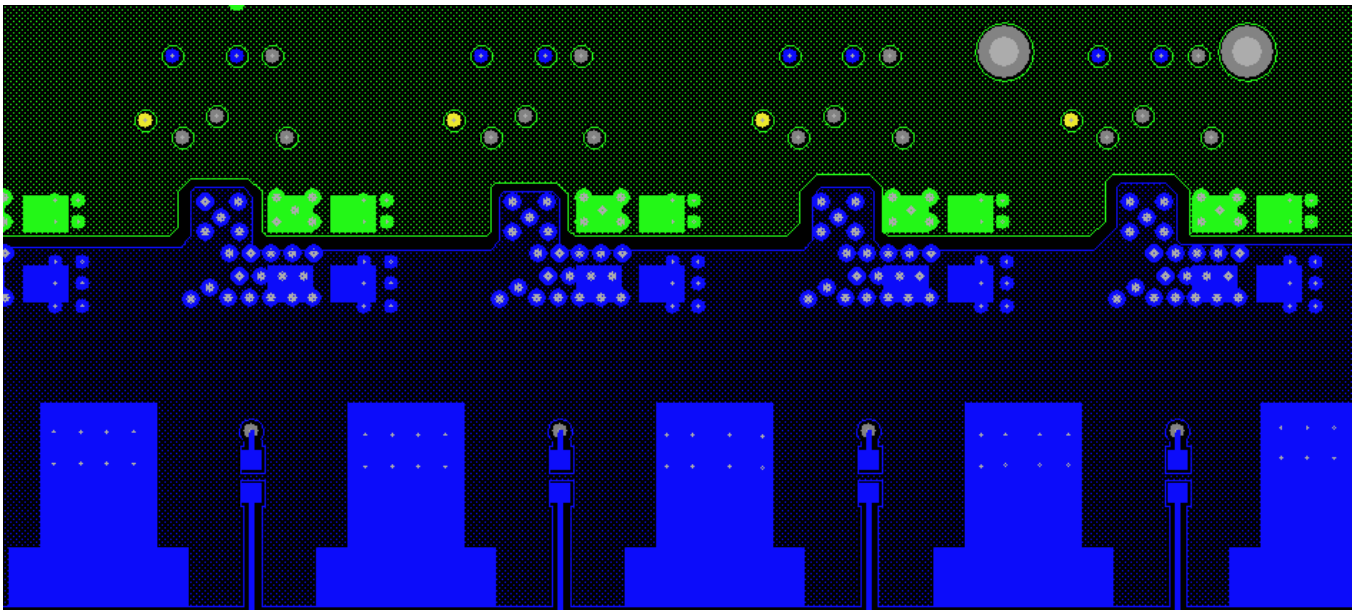

FIGURE 17. MULTIPHASE PCB LAYOUT EXAMPLE BOTTOM LAYER

ISL99227, ISL99227B

Revision History The revision history provided is for informational purposes only and is believed to be accurate, but not warranted. Please go to the web to make sure that you have the latest revision.

DATE	REVISION	CHANGE
October 27, 2016	FN8684.2	Updated Ordering Information table on page 5 to show all Released parts. Added "for dual footprint, a device compatible with ISL99227" on page 13 Updated Figures 16 and 17 for dual footprint on page 15
September 28, 2016	FN8684.1	Updated POD to revision 2 which added additional dimensions to the typical recommended land pattern and bottom views, and eliminated Note 6 which repeated the sentiments in the first line of Note 5.
August 30, 2016	FN8684.0	Initial Release

About Intersil

Intersil Corporation is a leading provider of innovative power management and precision analog solutions. The company's products address some of the largest markets within the industrial and infrastructure, mobile computing and high-end consumer markets.

For the most updated datasheet, application notes, related documentation and related parts, please see the respective product information page found at www.intersil.com.

You may report errors or suggestions for improving this datasheet by visiting www.intersil.com/ask.

Reliability reports are also available from our website at www.intersil.com/support.

For additional products, see www.intersil.com/en/products.html

Intersil products are manufactured, assembled and tested utilizing ISO9001 quality systems as noted in the quality certifications found at www.intersil.com/en/support/qualandreliability.html

Intersil products are sold by description only. Intersil Corporation reserves the right to make changes in circuit design, software and/or specifications at any time without notice. Accordingly, the reader is cautioned to verify that data sheets are current before placing orders. Information furnished by Intersil is believed to be accurate and reliable. However, no responsibility is assumed by Intersil or its subsidiaries for its use; nor for any infringements of patents or other rights of third parties which may result from its use. No license is granted by implication or otherwise under any patent or patent rights of Intersil or its subsidiaries.

For information regarding Intersil Corporation and its products, see www.intersil.com

Package Outline Drawing

L32.5x5V

32 LEAD DOUBLE COOLING QUAD FLAT NO-LEAD PLASTIC PACKAGE

Rev 2 9/16

For the most recent package outline drawing, see [L32.5x5V](#).

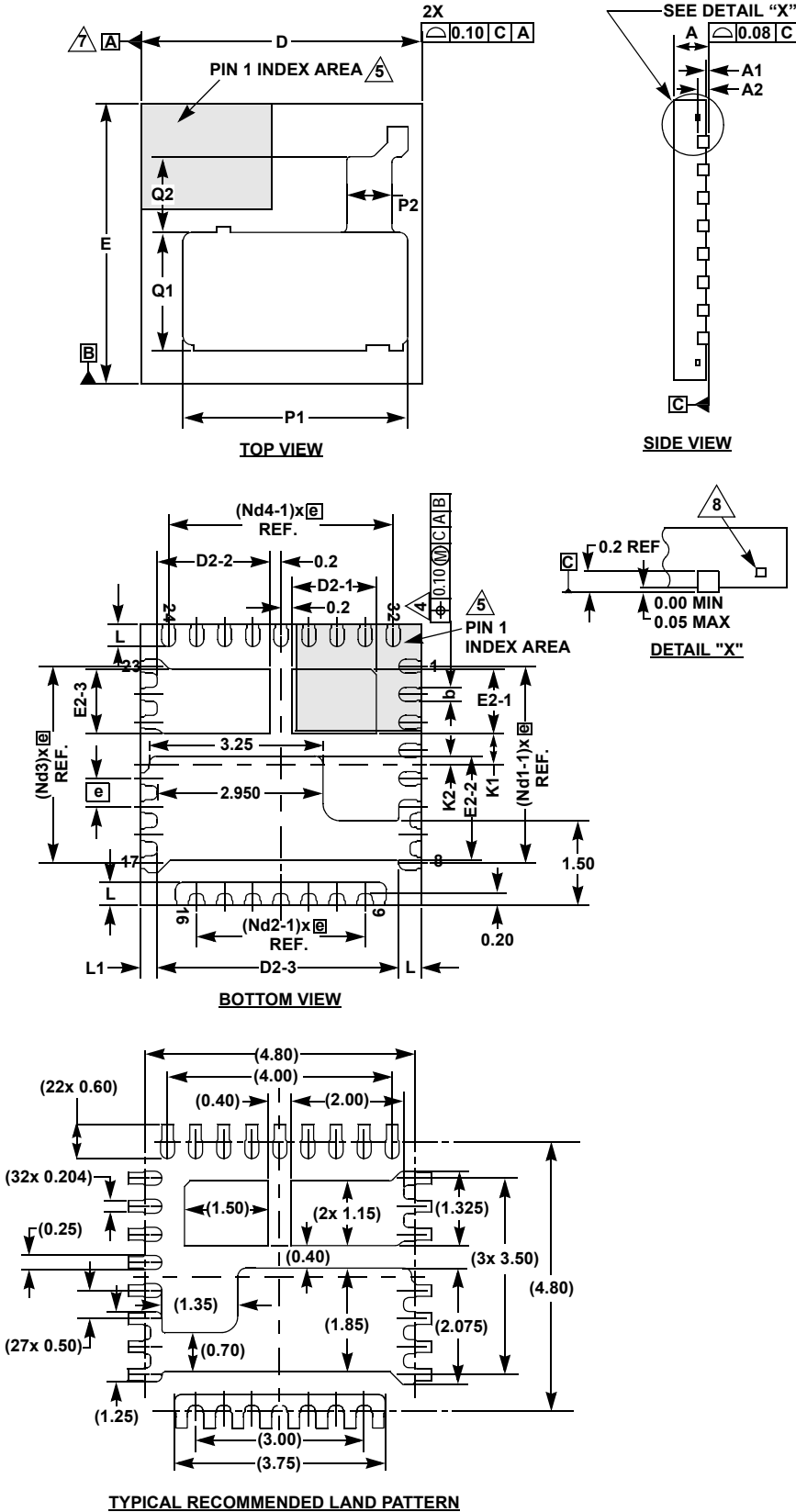

SYMBOL	MILLIMETERS		
	MIN	NOM	MAX
A (Note 7)	0.56	0.61	0.66
A1	0.00	-	0.05
A2	0.20 REF.		
b (Note 4)	0.20	0.25	0.30
D	5.00 BSC		
D2-1	1.45	1.50	1.55
D2-2	1.95	2.00	2.05
D2-3	4.25	4.30	4.35
e	0.50 BSC		
E	5.00 BSC		
E2-1	1.10	1.15	1.20
E2-2	1.80	1.85	1.90
E2-3	1.10	1.15	1.20
K1	0.55 BSC		
K2	0.15 BSC		
L	0.35	0.40	0.45
L1	0.25	0.30	0.35
P1	3.95	4.00	4.05
P2	0.75	-	1.15
Q1	2.05	2.10	2.15
Q2	1.30	1.35	1.40
N (Note 3)	32		
Nd1 (Note 3)	8 (PIN1~PIN8)		
Nd2 (Note 3)	8 (PIN9~PIN16)		
Nd3 (Note 3)	7 (PIN17~PIN23)		
Nd4 (Note 3)	9 (PIN24~PIN32)		

NOTES:

- Use millimeters as the primary measurement.
- Dimensioning and tolerances conform to ASME Y14.5M-1994.
- N is the number of terminals.
Nd1 and Nd3 is the number of terminals in Y-direction and Nd2 and Nd4 is the number of terminals in X-direction.
- Dimension b applies to plated terminal and is measured between 0.20mm and 0.25mm from terminal tip.
- The configuration of the pin #1 identifier is optional, but must be located within the zone indicated. The pin #1 identifier may be either a mold or mark feature.
- Package warpage MAX 0.08mm.
- Applied only for terminals.
- Tiebar shown (if present) is a non-functional feature.