



SAS-3 VERTICAL SMT RECEPTACLE

BOARD LAYOUT AND ROUTING GUIDELINES

TABLE OF CONTENTS

1.0 SCOPE

2.0 PC BOARD REQUIREMENTS

- 2.1 MATERIAL THICKNESS
- 2.2 LAYOUT

3.0 HIGH SPEED ROUTING

- 3.1 TRACE TO PAD ATTACHMENT
- 3.2 GROUD VIA PLACEMENT
- 3.3 IMPEDANCE MATCHING AT TRACE AND FOOTPRINT/PAD
- 3.4 HIGH SPEED REFERENCE PLANE ANTI-PAD
- 3.5 SKEW COMPENSATION FOR DIFFERENTIAL ROUTING
- 3.6 TRACE COMPARISON

REVISION:	ECR/ECN INFORMATION:	TITLE:	SHEET No.
D	EC No: S2014-1265 DATE: 2014/06/23	SI BOARD LAYOUT AND ROUTING GUIDELINE FOR SAS-3 VERTICAL SURFACE MOUNT RECEPTACLE	1 of 7
DOCUMENT NUMBER:	CREATED / REVISED BY:	CHECKED BY:	APPROVED BY:
AS-78715-001	CMWONG 2014/06/23	HELVY 2014/06/23	WTCHUA 2014/06/23



SAS-3 VERTICAL SMT RECEPTACLE

BOARD LAYOUT AND ROUTING GUIDELINES

1.0 SCOPE

This board layout and routing guidelines cover the printed circuit board layout that can be used for the evaluation of high-speed signals using microstrip routing for 78715 series connector.

Disclaimer: Molex does not guarantee the performance of the final product to the information provided in this document. All information in this report is considered Molex proprietary and confidential. This guide is not intended as a substitute for engineering analysis where optimization for signal integrity (SI) performance can be critical.

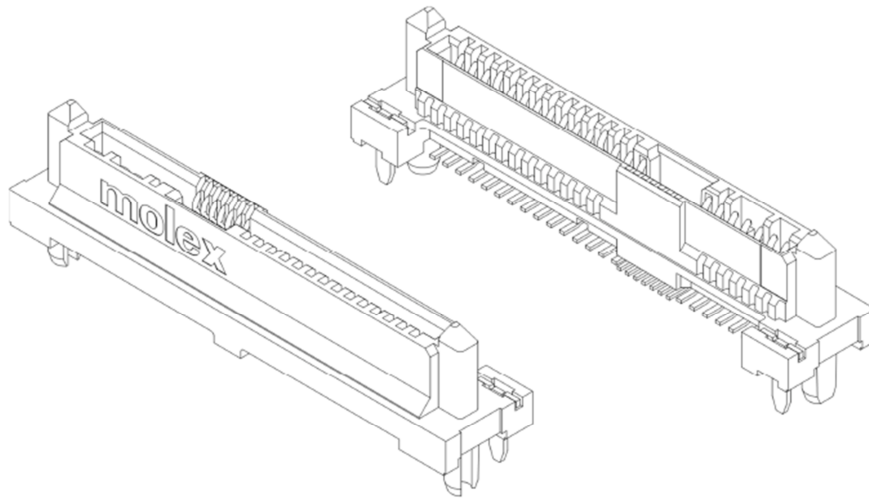

2.0 PC BOARD REQUIREMENTS

2.1 MATERIAL THICKNESS

The recommended PC board thickness shall be 1.60mm. Suitable PC board material shall be glass epoxy (FR-4).

2.2 LAYOUT

The solder pads for the connector assembly must be precisely located to ensure proper placement and optimum performance of the connector assembly. Refer to the applicable Sales Drawing for the recommended solder pad pattern, dimensions and tolerances.

REVISION: D	ECR/ECN INFORMATION: EC No: S2014-1265 DATE: 2014/06/23	TITLE: SI BOARD LAYOUT AND ROUTING GUIDELINE FOR SAS-3 VERTICAL SURFACE MOUNT RECEPTACLE	SHEET No. 2 of 7
DOCUMENT NUMBER: AS-78715-001	CREATED / REVISED BY: CMWONG 2014/06/23	CHECKED BY: HELVY 2014/06/23	APPROVED BY: WTCHUA 2014/06/23



SAS-3 VERTICAL SMT RECEPTACLE

BOARD LAYOUT AND ROUTING GUIDELINES

3.0 HIGH SPEED ROUTING

3.1 TRACE TO PAD ATTACHMENT

There are several ways to connect the traces to their corresponding signal pads. Two possible methods are illustrated in Figures 1 and 2.

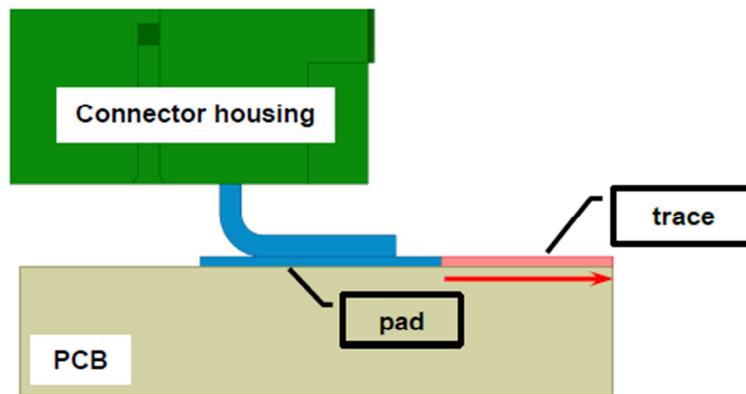

Figure 1

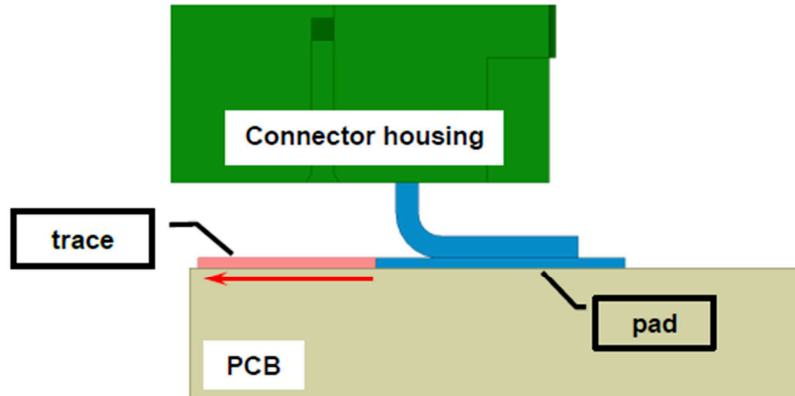

Figure 2

As seen in Figure 1, trace routed outwards from pad of connector will result in minimum pad stub while worst case pad stub occurs when trace is routed inwards as shown in Figure 2.

REVISION:	ECR/ECN INFORMATION:	TITLE:	SHEET No.
D	EC No: S2014-1265 DATE: 2014/06/23	SI BOARD LAYOUT AND ROUTING GUIDELINE FOR SAS-3 VERTICAL SURFACE MOUNT RECEPTACLE	3 of 7
DOCUMENT NUMBER:	CREATED / REVISED BY:	CHECKED BY:	APPROVED BY:
AS-78715-001	CMWONG 2014/06/23	HELVY 2014/06/23	WTCHUA 2014/06/23



SAS-3 VERTICAL SMT RECEPTACLE

BOARD LAYOUT AND ROUTING GUIDELINES

3.2 GROUND VIA PLACEMENT

There are several ways to connect ground vias to their corresponding ground pads. Two possible methods are illustrated in Figures 3 and 4.

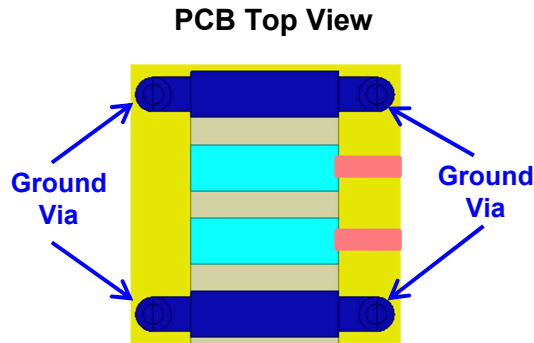

Figure 3

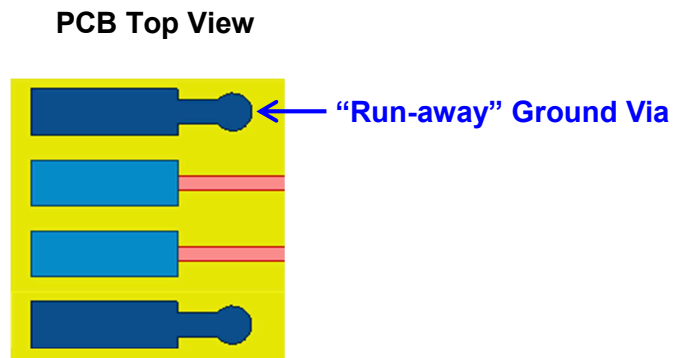

Figure 4

As seen in Figure 3, ground vias can be attached to both ends of ground pad for better signal return path. If this is not possible due to routing constrain, “run-away” ground vias from ground pads should follow the direction where the signal traces were attached to their corresponding signal pads as shown in Figure 4.

REVISION:	ECR/ECN INFORMATION:	TITLE:	SHEET No.	
D	EC No: S2014-1265 DATE: 2014/06/23	SI BOARD LAYOUT AND ROUTING GUIDELINE FOR SAS-3 VERTICAL SURFACE MOUNT RECEPTACLE	4 of 7	
DOCUMENT NUMBER:	CREATED / REVISED BY:	CHECKED BY:	APPROVED BY:	
AS-78715-001	CMWONG 2014/06/23	HELVY 2014/06/23	WTCHUA 2014/06/23	



SAS-3 VERTICAL SMT RECEPTACLE

BOARD LAYOUT AND ROUTING GUIDELINES

3.3 IMPEDANCE MATCHING AT TRACE AND FOOTPRINT/PAD

Impedance matching is critical to improve and optimize SI performance.

All traces and pad should design to obtain single-end 50Ω or differential 100Ω at application.

This could be done by controlling distance between trace (H_{trace}) and pad (H_{pad}) with reference to their ground return. This is illustrated in Figure 5.

When the trace width of pad equals to trace, H_{trace} equals H_{pad} . If pad width is wider than trace, $H_{\text{pad}} > H_{\text{trace}}$. This is to eliminate excessive capacitive coupling at pad region.

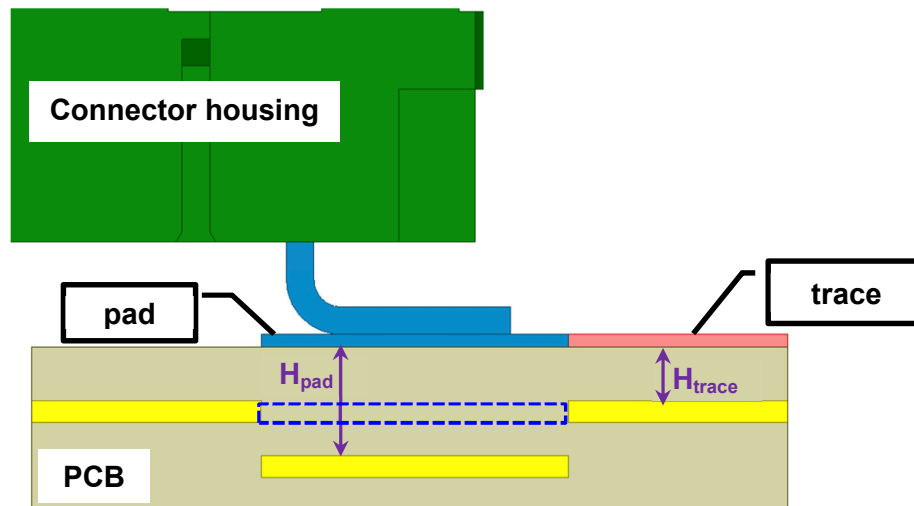

Figure 5

REVISION:	ECR/ECN INFORMATION:	TITLE:	SHEET No.
D	EC No: S2014-1265 DATE: 2014/06/23	SI BOARD LAYOUT AND ROUTING GUIDELINE FOR SAS-3 VERTICAL SURFACE MOUNT RECEPTACLE	5 of 7
DOCUMENT NUMBER:	CREATED / REVISED BY:	CHECKED BY:	APPROVED BY:
AS-78715-001	CMWONG 2014/06/23	HELVY 2014/06/23	WTCHUA 2014/06/23



SAS-3 VERTICAL SMT RECEPTACLE

BOARD LAYOUT AND ROUTING GUIDELINES

3.4 HIGH SPEED REFERENCE PLANE ANTI-PAD

An antipad or copper cutout region, shown in Figure 6, is needed to obtain desirable H_{pad} for impedance optimization. A table containing suggested values are shown in Table 1.

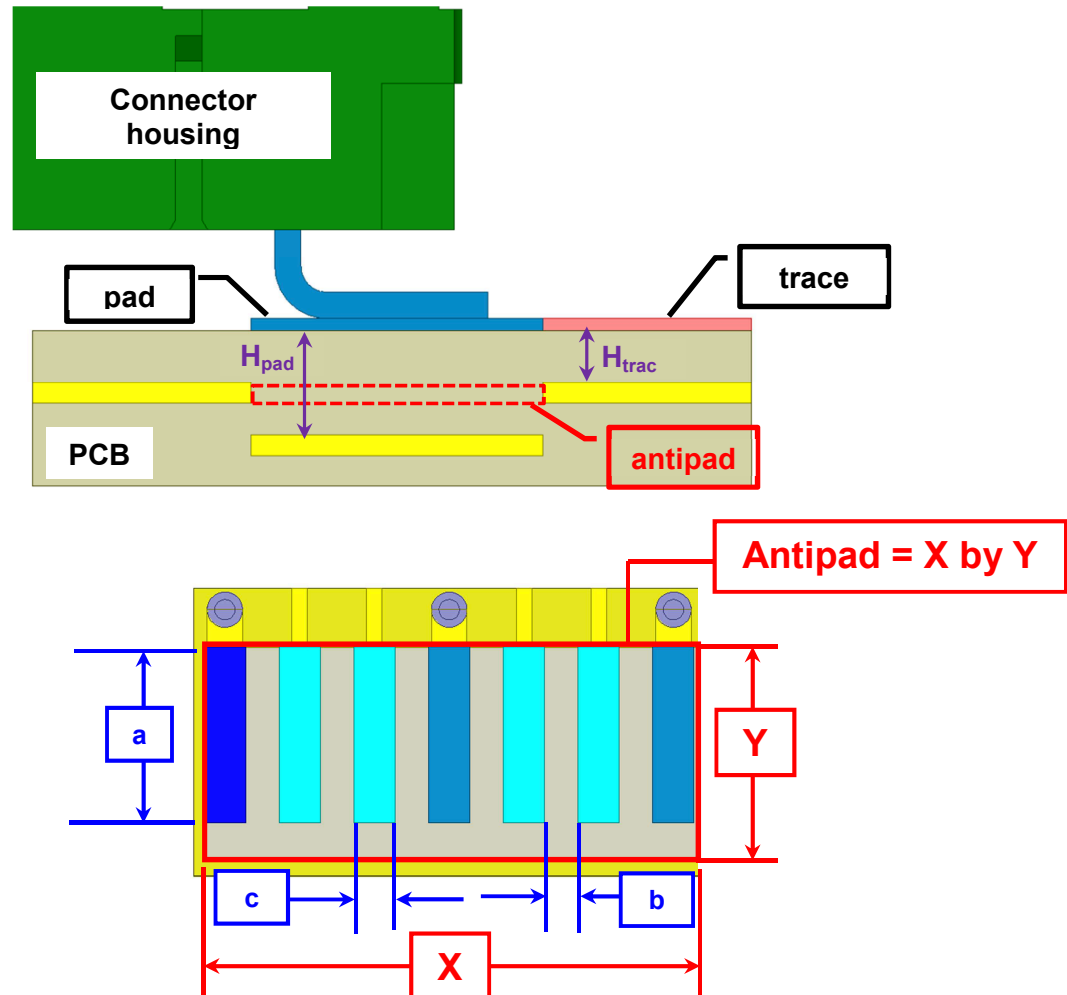

Figure 6 – Port Footprint

Antipad Dimension	Primary/Secondary Port
X	$7c + 6b$
Y	$a + b$

Table 1

Note: Anti-pad was implemented for impedance matching. Dimensions can vary from recommendation to meet electrical requirements. For example, the anti-pad can be made larger with a broader keep-out region on non-signal ground planes to minimize parasitic capacitance.

REVISION: D	ECR/ECN INFORMATION: EC No: S2014-1265 DATE: 2014/06/23	TITLE: SI BOARD LAYOUT AND ROUTING GUIDELINE FOR SAS-3 VERTICAL SURFACE MOUNT RECEPTACLE	SHEET No. 6 of 7
DOCUMENT NUMBER: AS-78715-001	CREATED / REVISED BY: CMWONG 2014/06/23	CHECKED BY: HELVY 2014/06/23	APPROVED BY: WTCHUA 2014/06/23



SAS-3 VERTICAL SMT RECEPTACLE

BOARD LAYOUT AND ROUTING GUIDELINES

3.5 SKEW COMPENSATION FOR DIFFERENTIAL ROUTING

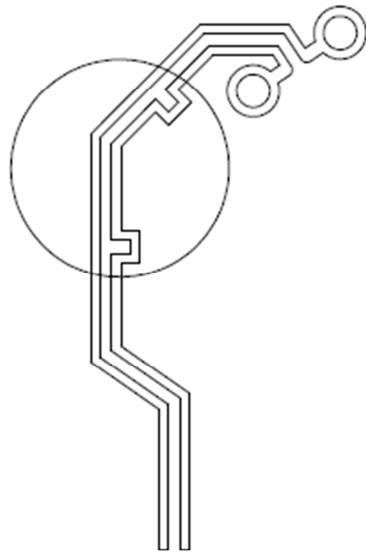

PREFERRED

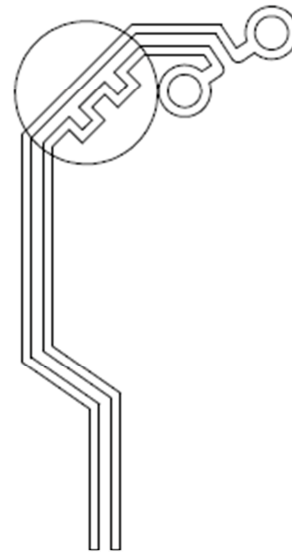

NOT RECOMMENDED

It is recommended that skew compensation be distributed versus grouped in one or more locations.

3.6 TRACE COMPARISON

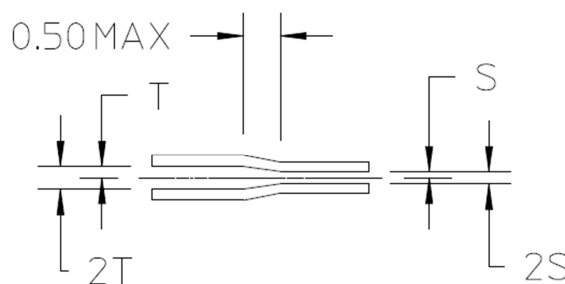

TRANSITION SHOULD BE SYMMETRIC

REVISION: D	ECR/ECN INFORMATION: EC No: S2014-1265 DATE: 2014/06/23	TITLE: SI BOARD LAYOUT AND ROUTING GUIDELINE FOR SAS-3 VERTICAL SURFACE MOUNT RECEPTACLE	SHEET No. 7 of 7
DOCUMENT NUMBER: AS-78715-001	CREATED / REVISED BY: CMWONG 2014/06/23	CHECKED BY: HELVY 2014/06/23	APPROVED BY: WTCHUA 2014/06/23