

REVISONS		DATE	BY	APVD
0	RLSE -1 PER NPR 222	07 MAR 00	DB	JK
A	REV PER EC OUID-44-00	07 MAR 00	DB	JK

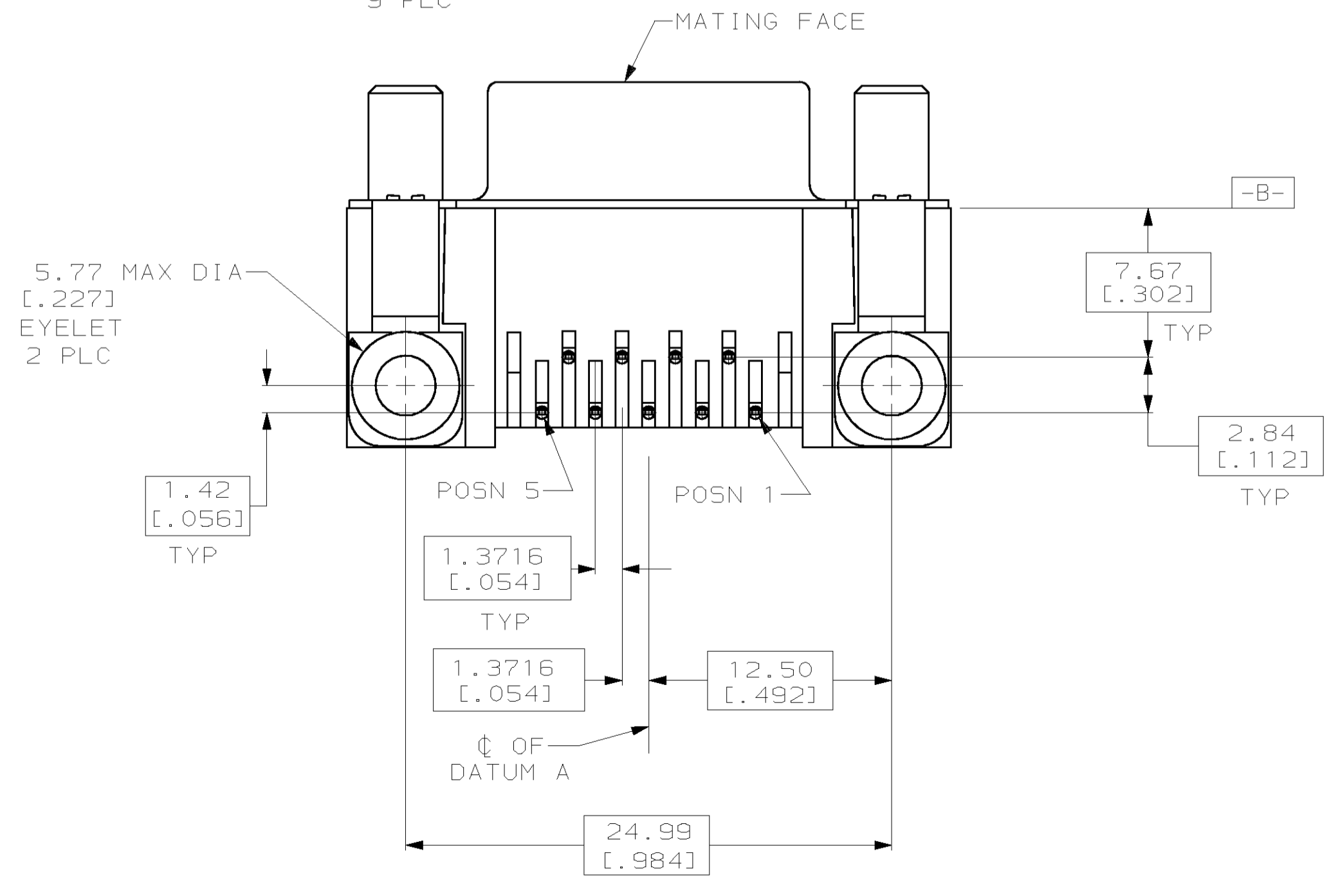
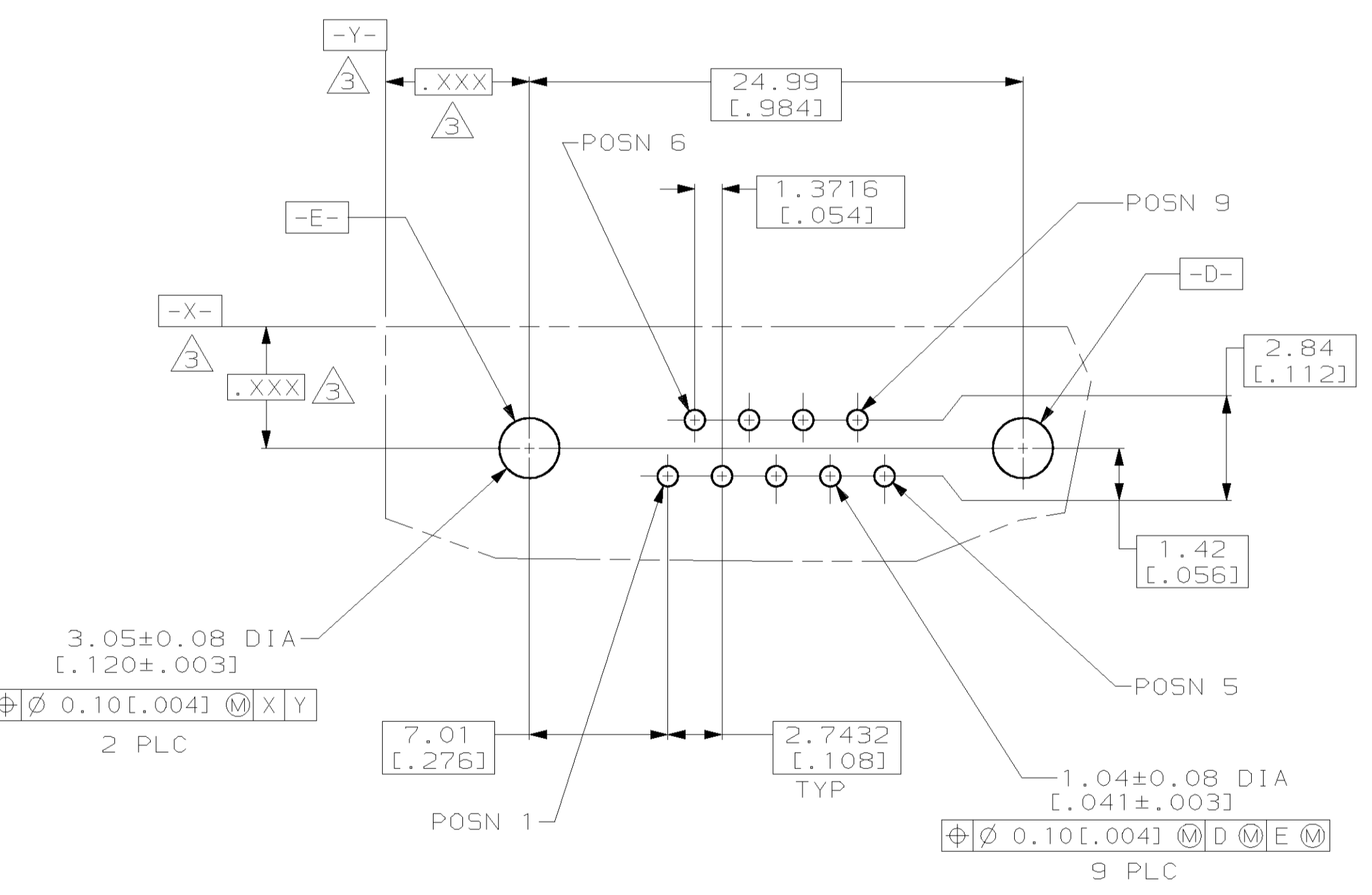
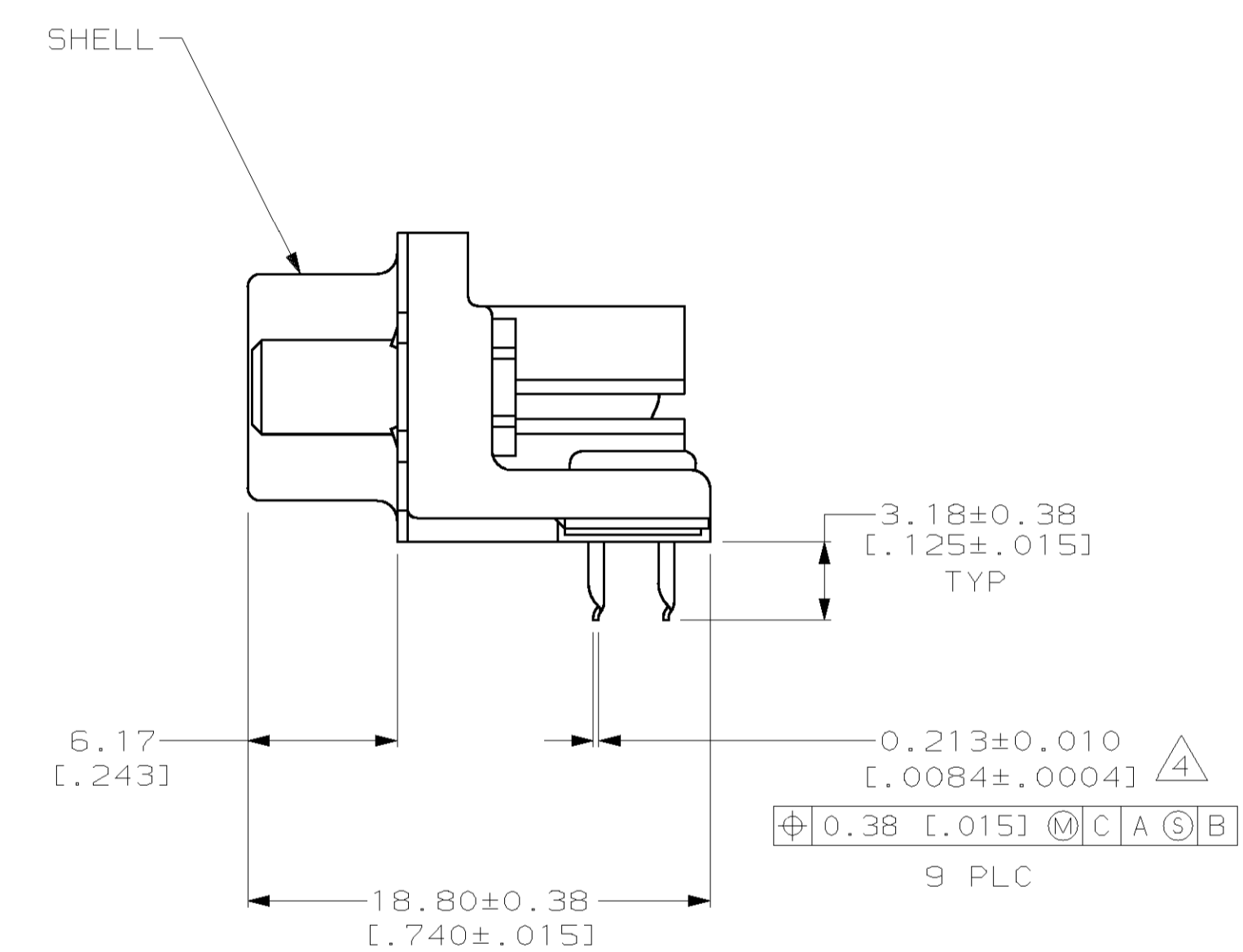
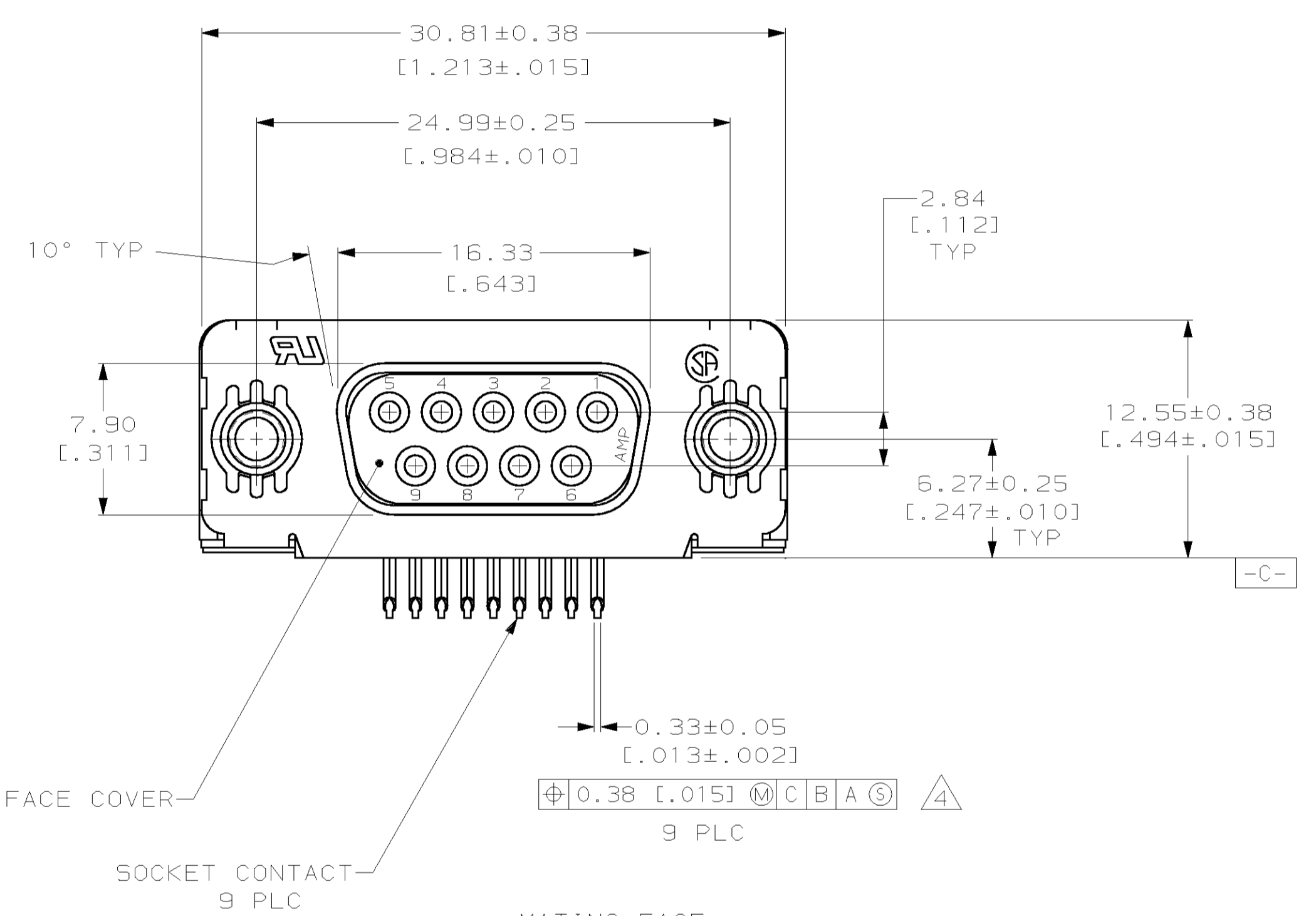
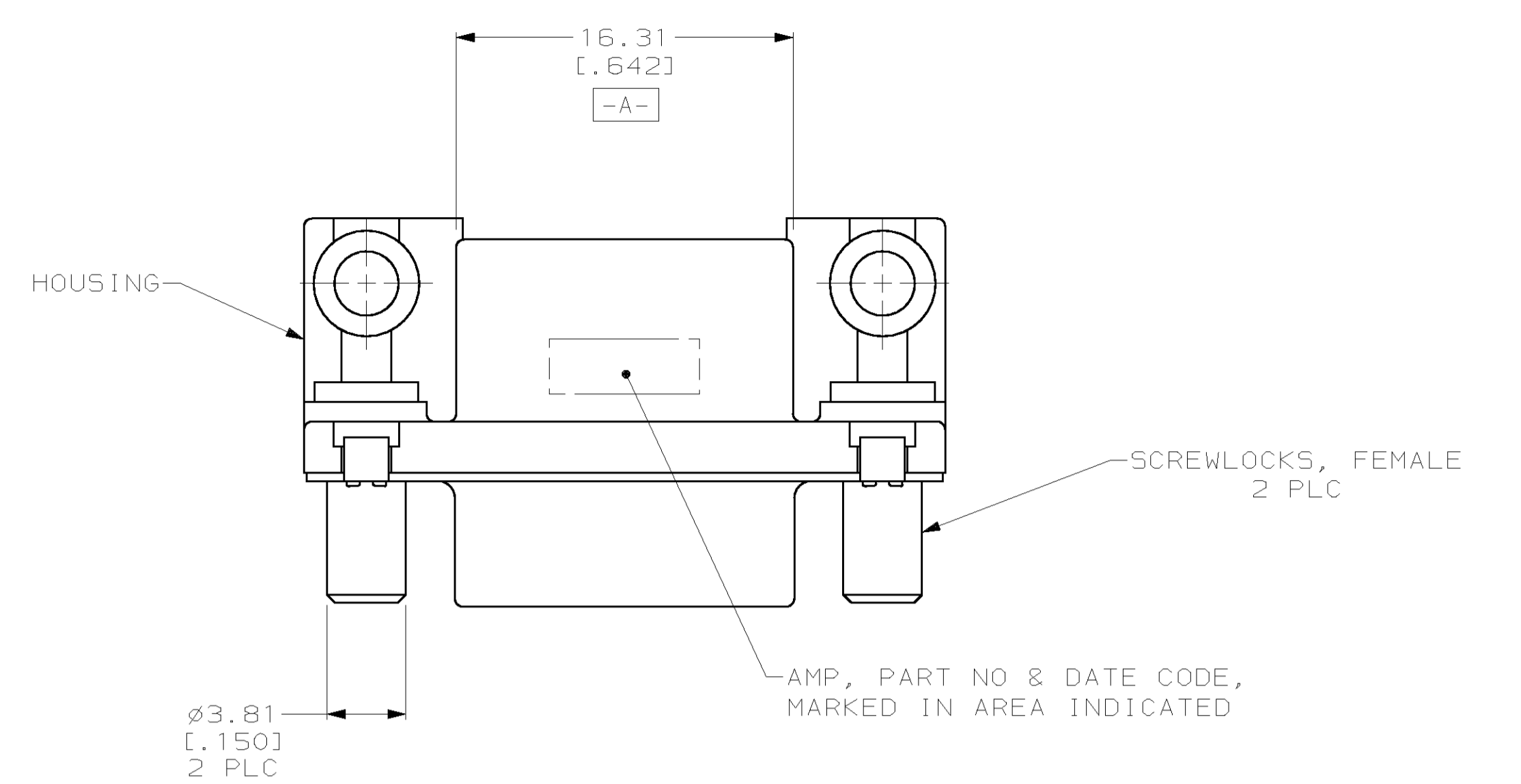

- 1. HOUSING & FACE COVER: NYLON, THERMOPLASTIC, UL 94V0 RATED, BLACK; SHELL: CARBON STEEL PER ASTM A109; SOCKET CONTACTS: PHOSPHOR BRONZE; PER QQ-B-750; EYELETS: BRASS; SCREWLOCKS: ZINC.
- 2. SOCKET CONTACTS: GOLD PLATED FOR A LENGTH OF 1.27 [.050] MIN FROM MATING END, 0.76µm [.000030] MIN GOLD IN MATED AREA, 2.54µm [.000100] MIN TIN OR TIN-LEAD FOR A LENGTH OF 3.56 [.140] MIN FROM OPPOSITE END, BOTH OVER 1.27µm [.000050] MIN NICKEL.
- 3. EYELETS: 2.54µm [.000100] MIN TIN-LEAD OR TIN OVER COPPER FLASH.
- 4. SHELL: 2.54µm [.000100] MIN TIN OVER 1.27µm [.000050] MIN COPPER.
- 5. SCREWLOCKS: CLEAR CHROMATE.
- 6. DATUMS AND BASIC DIMENSIONS ESTABLISHED BY CUSTOMER.
- 7. POSITION TOLERANCE APPLIES AT CONTACT TIP.
- 8. COMPATIBLE WITH TYPICAL HIGH TEMPERATURE SOLDERING APPLICATIONS TO A MAXIMUM OF 225°C FOR A MAXIMUM DURATION OF 90 SECONDS. TEMPERATURE TO BE MEASURED ON CONNECTOR SURFACE.

788803-1
PART NO

THIS DRAWING IS A CONTROLLED DOCUMENT AND IS UNPUBLISHED. IT IS SUBJECT TO CHANGE AND THE CONTROLLING ENGINEERING ORGANIZATION SHALL BE CONTACTED FOR THE LATEST REVISION.		DWG: D. BROCKWAY 07 MAR 00 CHK: J. KOPPENHEFFER 07 MAR 00 APVD: J. KOPPENHEFFER 07 MAR 00	NAME: AMP Incorporated Harrisburg, PA 17105-3608
DIMENSIONS: mm (INCHES)	TOLERANCES UNLESS OTHERWISE SPECIFIED: 0 PLC ±. 1 PLC ±. 2 PLC ±0.13 (.005) 3 PLC ±. 4 PLC ±. DIMENSIONS ±.2°	PRODUCT SPEC: 108-40025 APPLICATION SPEC: 114-40010	NAME: RCPT ASSEMBLY, SIZE 1, .318 SERIES, WITH FRONT METAL SHELL, HIGH TEMPERATURE, AMPLIMITE™ HD-20
MATERIAL	FINISH	WEIGHT	SCALE: 4:1
CUSTOMER DRAWING		SIZE: A1 CAGE CODE: 00779 DRAWING NO: 788803	SHEET: 1 OF 1 REV: A