

THIS DRAWING IS UNPUBLISHED. RELEASED FOR PUBLICATION, 19 .
 © COPYRIGHT 19 BY AMP INCORPORATED. ALL INTERNATIONAL RIGHTS RESERVED.

LOC	DIST	P	F	ZONE	LTR	REVISIONS	DATE	APPD
AF	50				B	ADD -2 PER PR94-65 & 0410-94	8/9/94	PF/DS

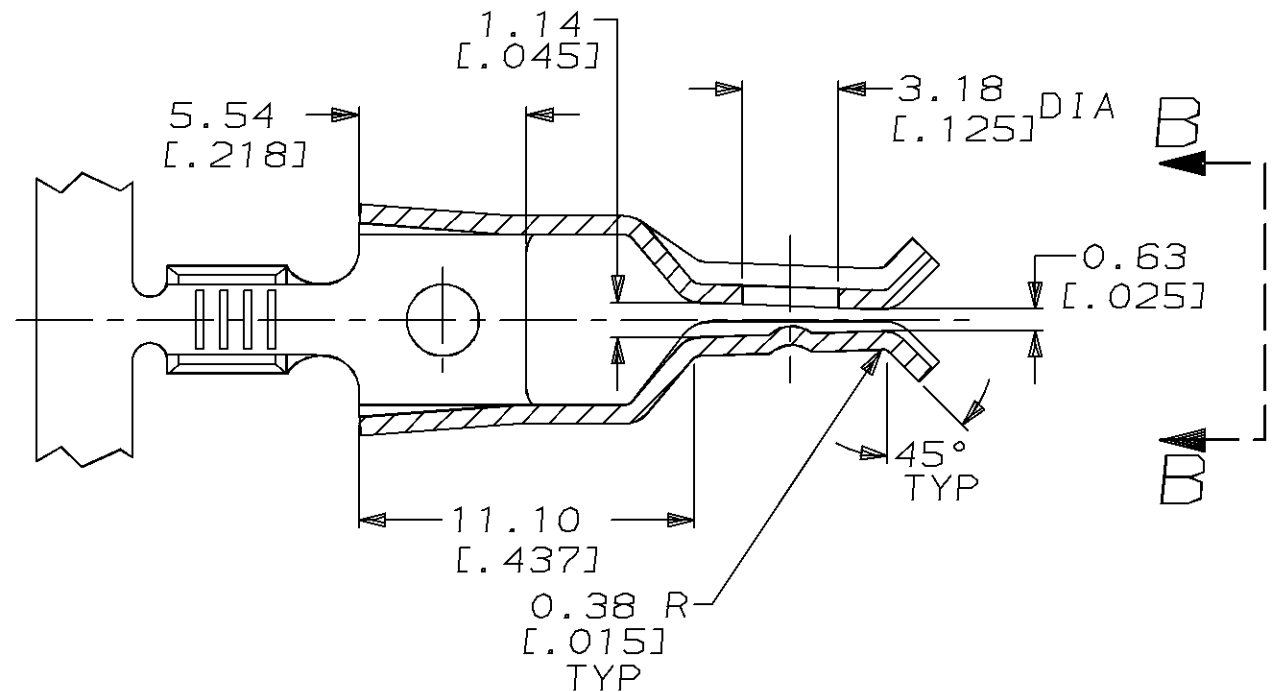

1 CONTINUOUS STRIP ON REEL.
 2 "P" STAMP ON 63723-2 ONLY.

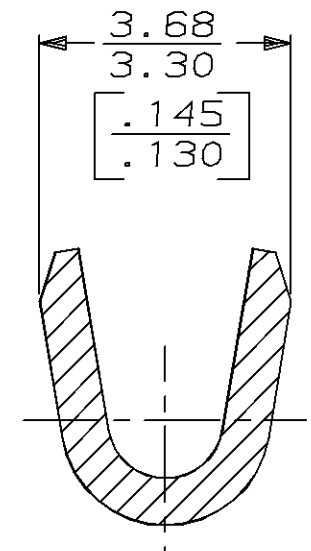
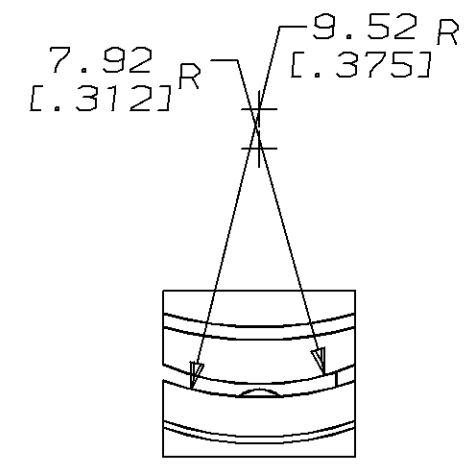

SECTION A-A
SCALE 10:1

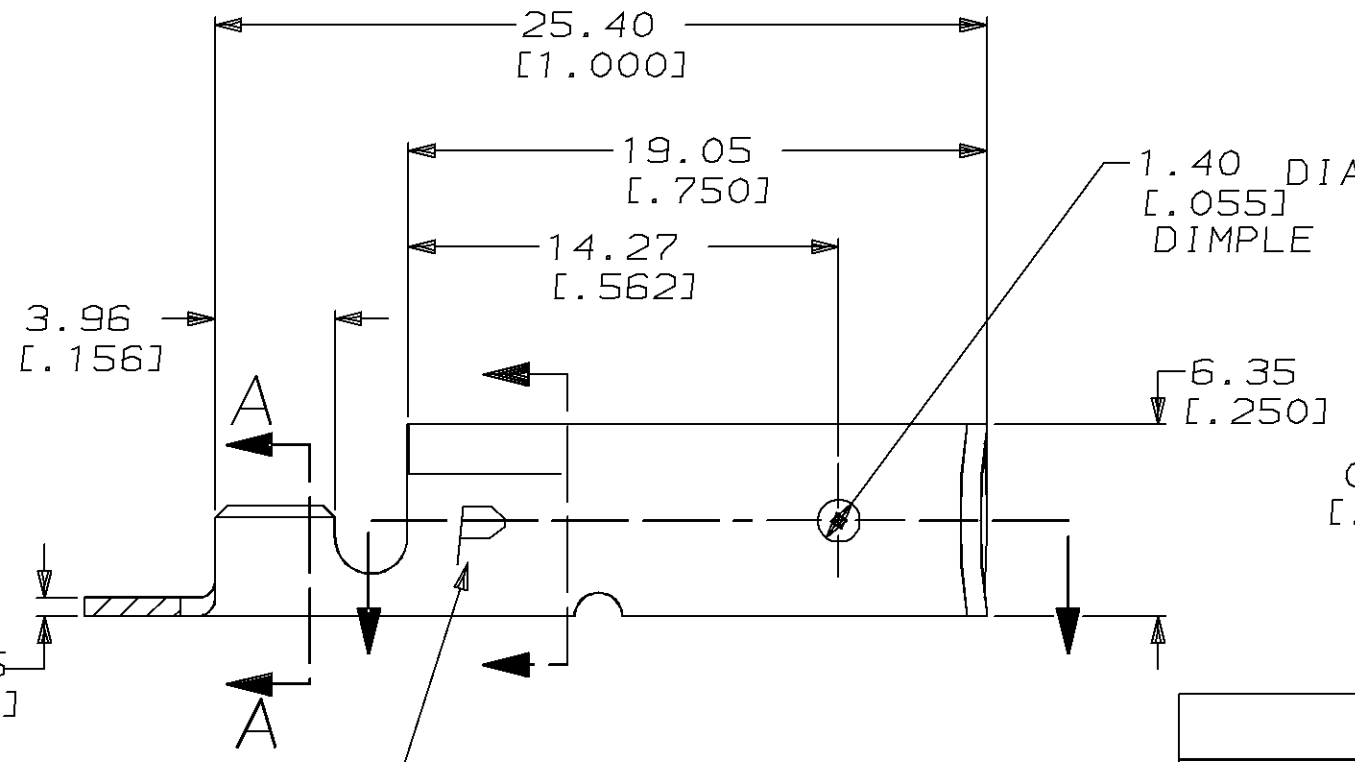

H04 PHOS BRONZE	0.5-1.3mm ²	△ 63723-2
T2 STEEL	[20-16] AWG	63723-1
WIRE RANGE		PART NO

DO NOT SCALE PRINT. UNLESS SPECIFIED DIMENSIONS IN mm [INCHES] TOLERANCES ON: 2 PLC DEC ± 0.25 [.010] 3 PLC DEC ± - ANGLES ± -	DR 7/29/93 PHIL FORTNEY
	CHK 7/29/93 JR RUTH
	APPD 7/29/93 D SCHWENK
	APPD 7/29/23 RON KUZO
MATERIAL SEE TABLE	PRODUCT SPEC -
FINISH 0.002032 [.000080] MIN TIN PL PER MIL-T-10727	APPLICATION SPEC - WEIGHT -

AMP AMP Incorporated Harrisburg, PA 17105-3608		
NAME RECEPTACLE		
SIZE B	CAGE CODE 00779	DRAWING NO C-63723
SCALE 4:1	SHEET 1 OF 1	

THIS DRAWING IS A CONTROLLED DOCUMENT FOR AMP INCORPORATED. IT IS SUBJECT TO CHANGE AND THE CONTROLLING ENGINEERING ORGANIZATION SHOULD BE CONTACTED FOR THE LATEST REVISION.