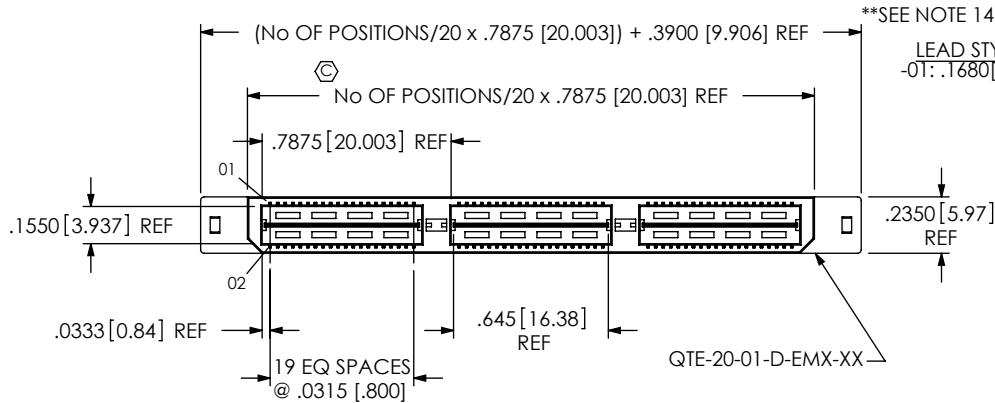

TABLE 2					
EDGE MOUNT THICKNESS	"A"	"B"	"C"	BODY	CONTACT
-EM2	.130[3.30]	.0670[1.702]	.058[1.47]	QTE-20-01-D-EM2-XX	T-1S42-01-XXX
*-EM3	.160[4.06]	.0980[2.489]	.088[2.24]	QTE-20-01-D-EM3-XX	T-1S42-02-XXX

* = SEE NOTE 13

QTE-XXX-01-XXX-D-EMX-XX



No OF POSITIONS
-020, -040, -060,
**-080, **-100
(PER ROW)

**SEE NOTE 14
LEAD STYLE
-01: .1680[4.267]

OPTION
-GP: GUIDE POST
(USE QTE-20-01-D-EMX-XX-GP,
SEE FIG 2, SHEET 2)
-TY: TRAY PACKAGING

EDGE MOUNT THICKNESS
-EM2: .064[1.63] +/- .004 PCB
(USE QTE-20-01-D-EM2-XX & T-1S42-01-X)
-EM3:
(USE QTE-20-01-D-EM3-XX & T-1S42-02-X)
SEE NOTE 13

ROW SPECIFICATION
-D: DOUBLE (USE QTE-20-XX-D-EMX-XX)

PLATING SPECIFICATION

No OF BANKS

-F: 3μ" SELECTIVE GOLD IN CONTACT AREA, MATTE TIN ON TAILS
(USE T-1S42-XX-F & T-1G1-01-F) (SEE NOTE 11)

-L: 10μ" SELECTIVE GOLD IN CONTACT AREA, MATTE TIN ON TAILS
(USE T-1S42-XX-L & T-1G1-01-L)

-H: 30μ" GOLD IN CONTACT AREA, 3μ" GOLD ON TAIL
(USE T-1S42-XX-H & T-1G1-01-G)

-C: 50μ" GOLD IN CONTACT AREA, 3μ" GOLD ON TAIL
(USE T-1S42-XX-C & T-1G1-01-L)

-STL: 30μ" SELECTIVE GOLD IN CONTACT AREA, TIN/LEAD (90%/10 +/-5%) TAIL
(USE T-1S42-XX-STL & T-1G1-01-STL)

-FTL: 3μ" SELECTIVE GOLD IN CONTACT AREA, TIN/LEAD (90%/10 +/-5%) TAIL
(USE T-1S42-XX-FTL & T-1G1-01-FTL)

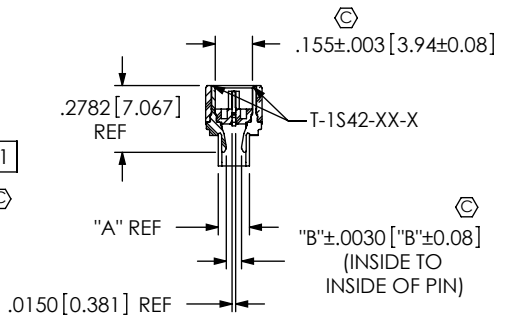
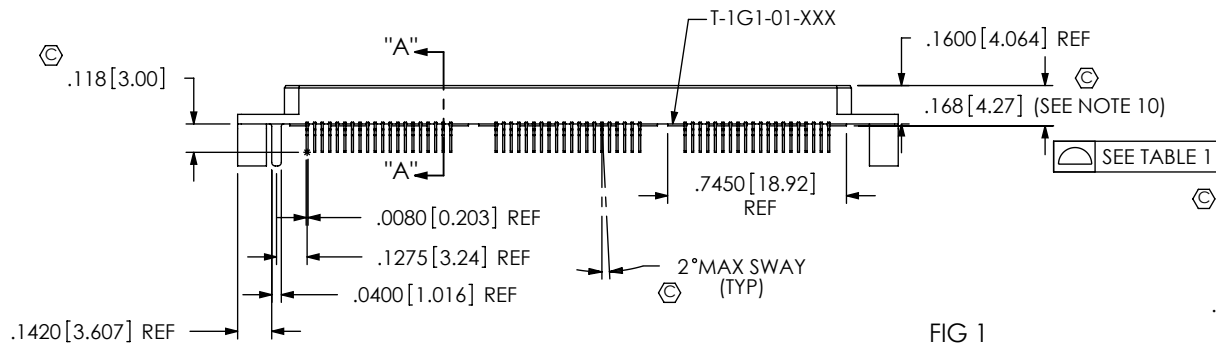
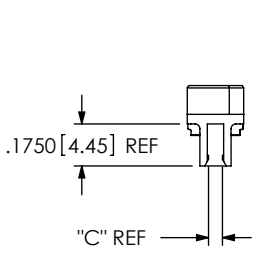

FIG 1
QTE-060-01-XXX-D-EM2 SHOWN

SECTION "A"- "A"

- NOTES:
1. Ⓢ REPRESENTS A CRITICAL DIMENSION.
 2. NOTE DELETED.
 3. BURR ALLOWANCE: .0015 [0.03] MAX.
 4. MINIMUM TERMINAL RETENTION: 6 OZ.
 5. MINIMUM GROUND PLANE RETENTION: 1 LB.
 6. PARTS TO BE MOLD-TO-POSITION.
 7. NOTE DELETED.
 8. NOTE DELETED.
 9. NOTE DELETED.
 10. MAX VARIANCE: .002 [0.05].
 11. -L PLATING CAN BE SUBSTITUTED FOR -F PLATING.
 12. SEE http://www.samtec.com/processing/edgemt_tectalk/index.htm FOR INFORMATION ON PROCESSING EDGE MOUNT PARTS TO BOARDS.
 13. -EM3 IS NOT A STANDARD OFFERING; AVAILABLE AS AN ASP ONLY. PLEASE CONTACT SAMTEC INTERCONNECT PROCESSING GROUP WITH ORDER INQUIRIES
 14. FOR NEW APPLICATIONS REQUIRING THESE POSITIONS, PLEASE CONTACT SAMTEC INTERCONNECT PROCESSING GROUP.
 15. PARTS WITHOUT -TY OPTION SHALL BE PACKAGED IN TRAYS.

TABLE 1		
No OF POSITIONS	GND PLANE COPLANARITY	ASSEMBLY BOW
-020 THRU -060	.004 [.10]	.004 [.10]
-080 THRU -100	.005[1.27]	.005[1.27]

UNLESS OTHERWISE SPECIFIED, DIMENSIONS ARE IN INCHES. TOLERANCES ARE: DECIMALS ANGLES .XX: ±.01 [3] 2° .XXX: ±.005 [13] .XXXX: ±.0020 [051]	PROPRIETARY NOTE THIS DOCUMENT CONTAINS INFORMATION CONFIDENTIAL AND PROPRIETARY TO SAMTEC, INC. AND SHALL NOT BE REPRODUCED OR TRANSFERRED TO OTHER DOCUMENTS OR DISCLOSED TO OTHERS OR USED FOR ANY PURPOSE OTHER THAN THAT WHICH IT WAS OBTAINED WITHOUT THE EXPRESSED WRITTEN CONSENT OF SAMTEC, INC.	520 PARK EAST BLVD, NEW ALBANY, IN 47150 PHONE: 812-944-6733 FAX: 812-948-5047 e-Mail: info@SAMTEC.com code: 55322

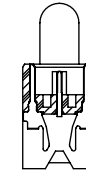
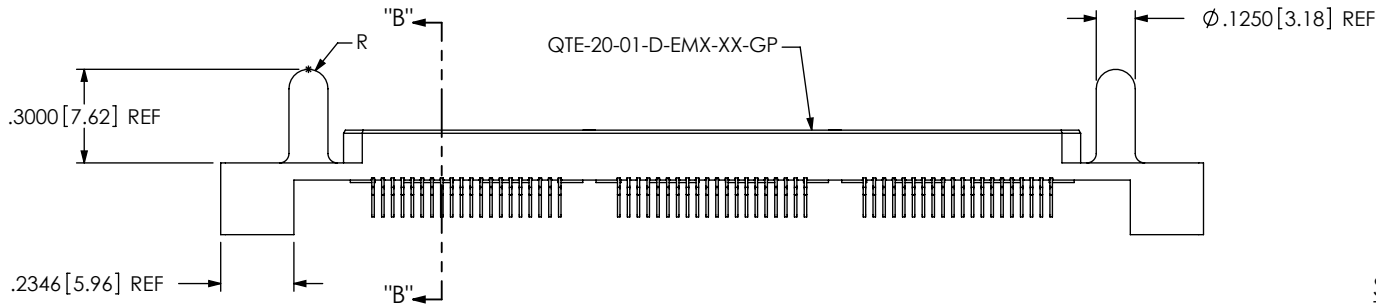
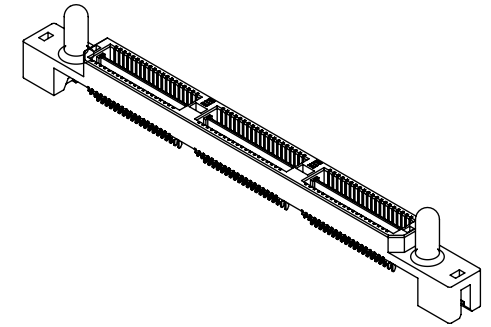
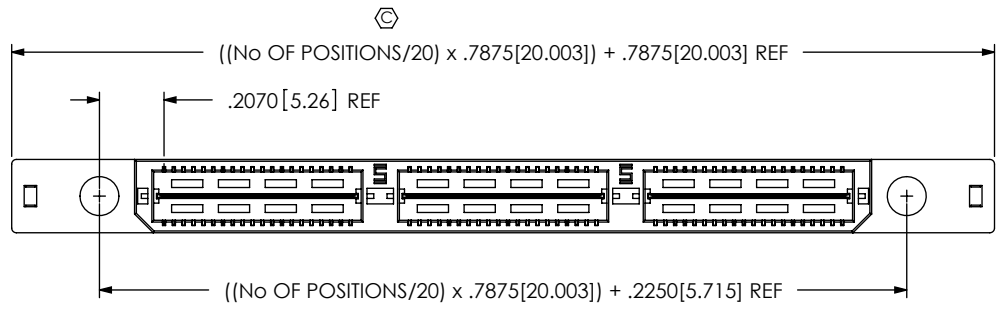

SECTION "B"-"B"

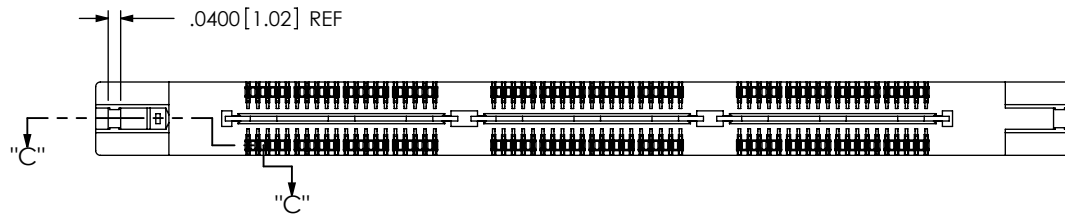
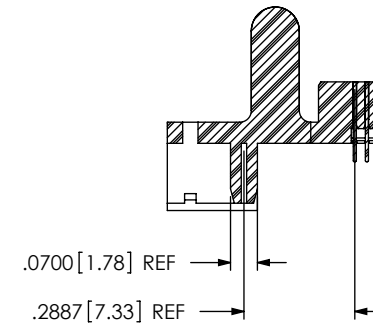

FIG 2
-GP OPTION
(SAME AS FIG 1, UNLESS OTHERWISE STATED)



SECTION "C"-"C"
SCALE 2 : 1

PROPRIETARY NOTE
 THIS DOCUMENT CONTAINS INFORMATION CONFIDENTIAL AND PROPRIETARY TO SAMTEC, INC. AND SHALL NOT BE REPRODUCED OR TRANSFERRED TO OTHER DOCUMENTS OR DISCLOSED TO OTHERS OR USED FOR ANY PURPOSE OTHER THAN THAT WHICH IT WAS OBTAINED WITHOUT THE EXPRESSED WRITTEN CONSENT OF SAMTEC, INC.

DO NOT SCALE DRAWING

SHEET SCALE: 1.625:1



520 PARK EAST BLVD, NEW ALBANY, IN 47150
 PHONE: 812-944-6733 FAX: 812-948-5047
 e-Mail: info@SAMTEC.com code: 55322

DESCRIPTION:
 .8mm EDGEMOUNT HS TERMINAL ASSEMBLY

DWG. NO.
QTE-XXX-01-XXX-D-EMX-XX

BY: DEAN P 9/2/1999 SHEET 2 OF 2