



Approval Sheet

for

**Metal Oxide Film Resistors
Power & Flame-Proof Type**

MOF series

$\pm 2\%$ & $\pm 5\%$

YAGEO CORPORATION

Headquarters: 3F, No.233-1, Pao Chiao Rd., Xindian, Taipei, Taiwan, R.O.C.

Tel: 886-2-6629-9999 **Fax:** 886-2-6628-8885

URL: www.yageo.com

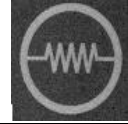

1. PRODUCT:

POWER METAL OXIDE FILM RESISTORS-Flame Proof Type
Body colour: Gray

2. PART NUMBER:

Part number of the power metal oxide film resistor is identified by the name, power, tolerance, packing, temperature coefficient, special type and resistance value.

Example :

MOF	3WV	J	T	-	77-	100R
(1)	(2)	(3)	(4)	(5)	(6)	(7)
Series Name	Power Rating	Resistance Tolerance	Packing Style	Temperature Coefficient of Resistance	Special Type	Resistance Value

- (1) Style: MOF SERIES
 - (2) Power Rating : 3WV=3W 、 4WV=4W
 - (3) Tolerance: G=±2% J=±5%
 - (4) Packaging Type: T=Tape on Box Packing
 - (5) Temperature Coefficient : ”-“=Base on spec.
 - (6) Special Type : 77-=77mm
 - (7) Resistance Value : E24 only, (E48 2% contact factory)
- Example : 1R 、 10R 、 100R 、 10K 、 100K.....

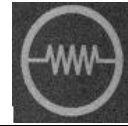

3. MARKING:

Printed in clear.

4. ELECTRICAL CHARACTERISTICS

TABLE I Ultra Miniature Style

STYLE	MOF3WV	MOF4WV
Power Rating at 70 °C	3W	4W
Max. Cont. Work. Voltage	750V	
Voltage Proof on Insulation (1min.)	500Vrms	
Thermal resistance _{cv} (°C/W)	<93	<70
Operating Temp. Range	- 55 °C to + 250 °C	
Temperature Coefficient	±200 ppm /°C	

TABLE II Resistance Range

Resistance Range		E Series	Tolerance	T.C.R
MOF3WV	MOF4WV			
0R22...560K	0R22...100K	E24	±5%	±200 ppm /°C

* Below or over this resistance on request.

5. DERATING CURVE

Rated Load (%)

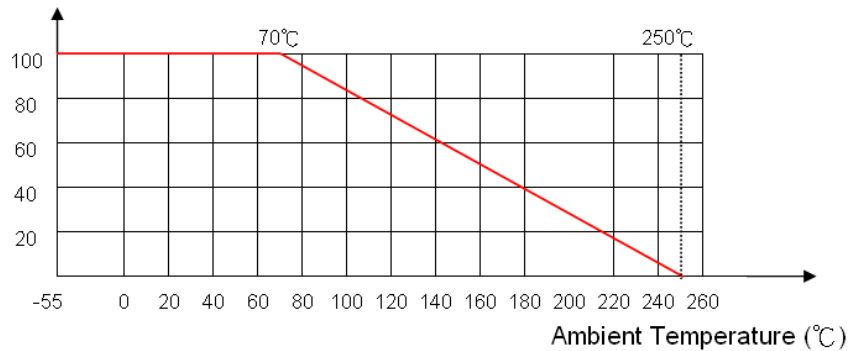

6. DIMENSIONS

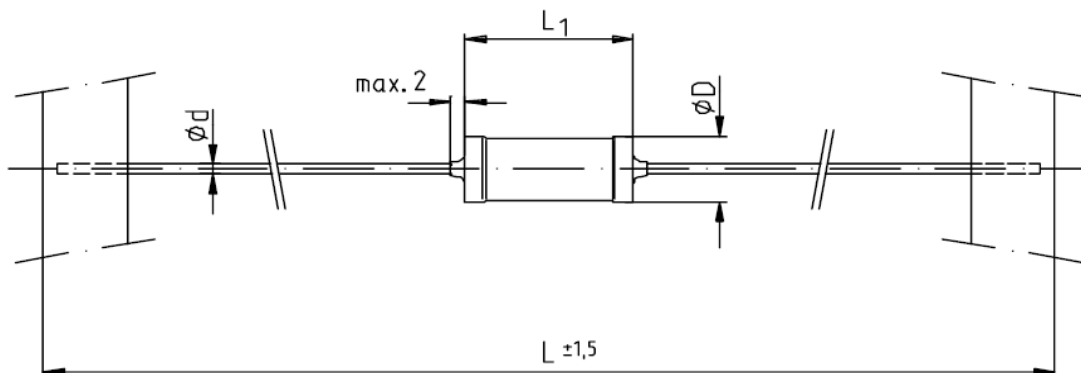



STYLE	DIMENSIONS (mm)				
	L1 max.	ψ D	ψ d	L ±1.5	Inside tape
MOF3WV	16.5 -1.5	6.0 -0.5	0.8±0.05	95	77
MOF4WV	20 -1	9.0 -0.5	0.8±0.05	95	77

7. ENVIRONMENTAL CHARACTERISTICS

(1) Short Time Overload

At 2.5 times of the rated voltage or max. overload voltage for 5 seconds, whichever is less; the resistor should be free from defects after the resistor is released from load for about 30 minutes

$$\text{Rated Voltage} = \sqrt{\text{Power Rating} \times \text{Resistance Value}}$$

The change of the resistance value should be within ± 2.0%

(2) Voltage Proof

The resistor shall be clamped in the trough of a 90° metal V Block. Apply the insulation voltage specified in the "Table I" between the terminals connected together with the block for about 60 seconds. The resistor shall be able to withstand without breakdown or flashover.

(3) Temperature Coefficient Test

Test of resistors above room temperature 100°C ± 2°C (Testing Temperature 115°C to 130°C) at the constant temperature silicon plate for over 5 minutes. Then measure the resistance value.

The Temperature Coefficient is calculated by the following equation and its value should be within the range of requested.

$$\text{Resistor Temperature Coefficient} = \frac{R - R_0}{R_0} \times \frac{1}{t - t_0} \times 10^6$$

R = Resistance value under the testing temperature

R₀ = Resistance value at the room temperature

t = The testing temperature

t₀ = Room temperature

(4) Solderability

Immerse the specimen into the solder pot at 245 ± 5 °C for 3 ± 0.5 seconds.

At least 95% solder coverage on the termination.

(5) Solvent Resistance of Marking

The specimen into the appropriate solvent of IPA condition of ultrasonic machine for 5± 0.5 minutes.

The specimen is no deterioration of coatings and color code

(6) Robustness of Terminations

Direct Load – Resistors shall be held by one terminal and the load shall be gradually applied in the direction of the longitudinal axis of the resistor unit the applied load reached the requirement.

The load shall be held for 10 seconds. The load of weight shall be ≥ 40N

(7) Damp Heat Steady State

Place the specimen in a test chamber at 40 ± 2 °C and 90 ~ 95 % relative humidity. Apply the 0.1 times rated voltage to the specimen at the 1.5 hours on and 0.5 hour off cycle. The total length of test is 56 days.

The change of the resistance value shall be within ± 1.5 %



(8) Endurance at 70 °C

Placed in the constant temperature chamber of 70 ± 3 °C the resistor shall be connected to the lead wire at the point of 25mm. Length with each terminal, the resistors shall be arranged not much effected mutually by the temperature of the resistors and the excessive ventilation shall not be performed, for 90 minutes on and 30 minutes off under this condition the rated D.C. voltage is applied continuously for 1000+48/-0 hours then left at no-load for 1hour, measured at this time the resistance value °

The change of the resistance value shall be within $\pm 1.5\%$

There shall be no remarkable change in the appearance and the color code shall be legible after the test..

(9) Resistance to Soldering Heat

The terminal lead shall be dipped into the solder pot at 260 ± 3 °C for 10 ± 1.0 seconds up to 2.5 ~ 3.5 mm.

The change of the resistance value shall be within $\pm 0.25\%$

8. PACKAGING

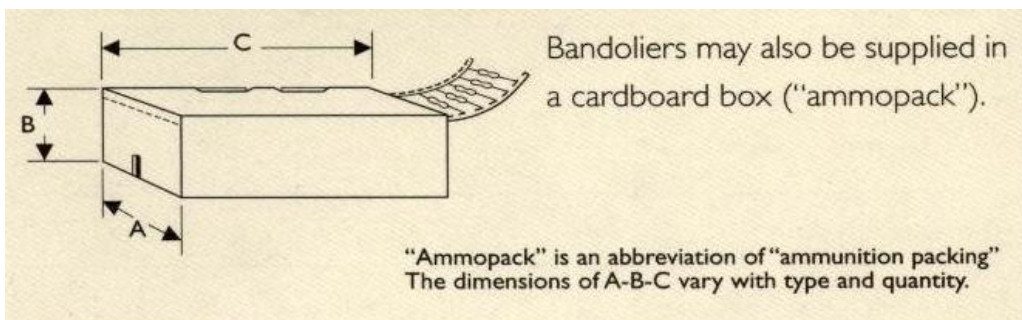

STYLE	Packaging	Standard Lead Length (Unit: mm)			Qty per box
		A	B	C	
Miniature					
MOF3WV	Taped / Ammo Pack	115	93	405	1,000
MOF4WV	Taped / Ammo Pack	118	110	412	500

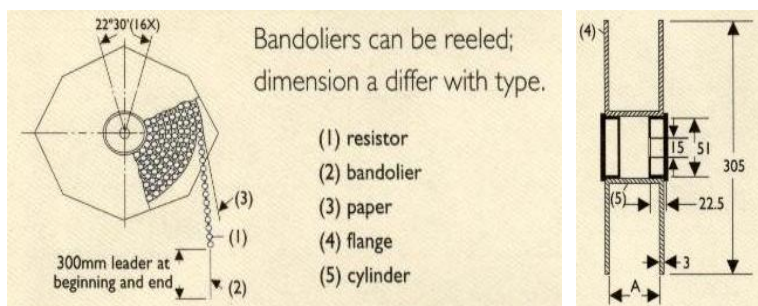

STYLE	Packaging	Across Flange (A)	Pieces
Miniature			
MOF3WV	Taped / Reel	95	1,500
MOF4WV	Taped / Reel	105	1,000

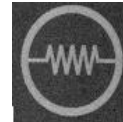

9. Plant Address

- A. China Dongguan Plant
7-1, Gaoli Road, Gaoli Industrial Zone
Tangxia Zhen, Dongguan, Guangdong, China
(廣東省東莞市塘廈鎮高麗工業區高麗路 7-1 號)
Tel. 86-769-8772 0275
Fax. 86-769-8772 0275 #4333

- B. China Mudu Plant
No.158, Fengjiang Road,
Mudu New District, Suzhou, Kiangsu, China
(江蘇省蘇州木瀆新區楓江路 158 號)
Tel. 86-512-6651 8889
Fax. 86-512-6651 9889