

DO NOT SCALE THIS DRAWING

31-343-RFX
DRAWING NUMBER

REVISIONS

SYM	DESCRIPTION	DATE	E.C.O. NO.	APPR.
A	OFFICIAL ENG. RELEASE TO MFG.	10/2/91	38063	LR

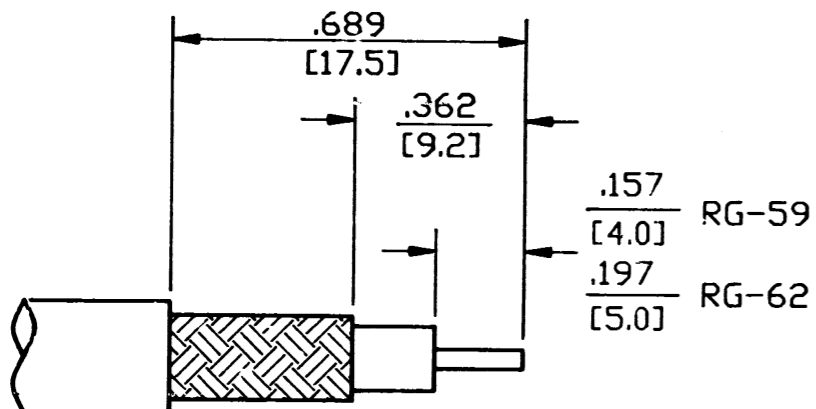

RECOMMENDED CABLE STRIPPING DIM'S

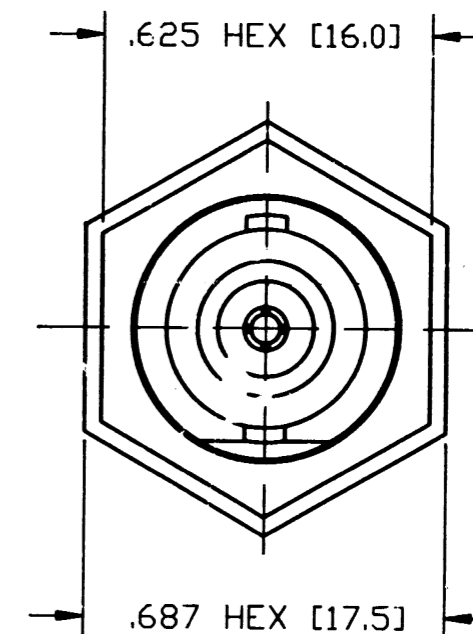
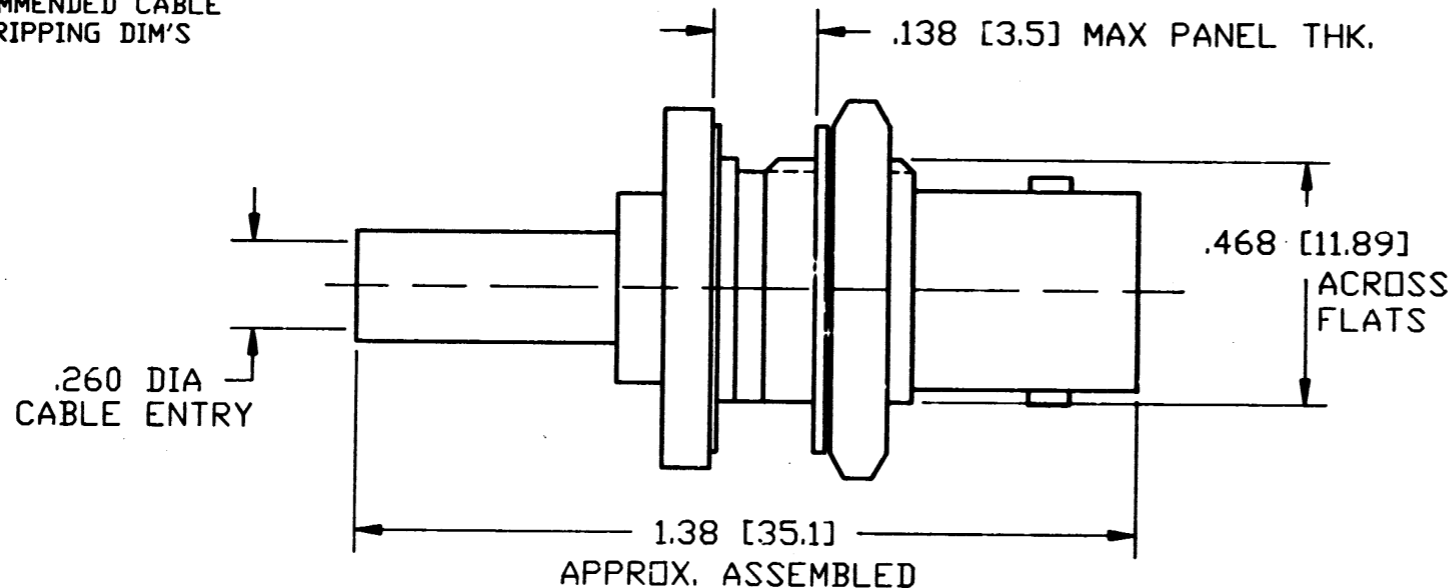
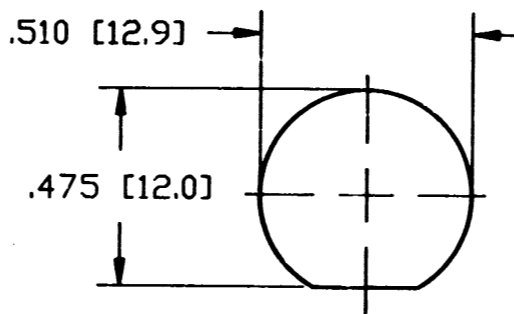

NOTES:

1. BRASS BODY, NICKEL PLATED.
2. DELRIN INSULATORS.
3. GOLD PLATED, PHOSPHOR BRONZE CONTACT, .000003.
4. PACKAGED IN BAG 999-358.
5. USE AMPHENOL CRIMP TOOL #CTL-1.
6. NON-CAPTIVATED CONTACT, .030 WIRE ENTRY.
7. 3 PC. (BODY, FERRULE, CONTACT).
8. BUSHING SUPPLIED FOR RG-62 CABLE.

ENGLISH [METRIC]

H:\DEPT611\BNC\031\ASSY\343RFX

PART NO.	QUAN	UOM	ITEM LINE NO.	DESCRIPTION	CODE	FINISH
LIST OF MATERIAL						

REMOVE ALL BURRS, BREAK CORNERS AND SHARP EDGES .005 MAXIMUM UNLESS OTHERWISE SPECIFIED.

NEXT ASSY	USED ON	UNLESS OTHERWISE SPECIFIED DIMENSIONS ARE IN INCHES. TOLERANCES NOT OTHERWISE SPECIFIED ARE:
		2 PLACE DECIMAL ±.015 (0.381 mm) 3 PLACE DECIMAL ±.005 (0.127 mm) ANGLES ± 1°
MATERIAL		REFERENCE DRAWING NO EAR 962370
SPECIFICATION		
FINISH		

DRAWN BY TERRI ALBERA	DATE 4-22-91
CHECKED <i>D.W. Payne</i>	DATE 3-13-91
ENGINEER <i>D.W. Payne</i>	DATE 3-13-91
QUALITY ASSURANCE <i>J. K.</i>	DATE 7/17/91
MFG. ENG. H. FREDLUND	DATE 9/19/91

TITLE BNC CRIMP CRIMP JACK FOR RG-59, 62 CABLE
CODE IDENTIFICATION 74868
DRAWING SIZE B
DRAWING NO. 31-343-RFX

Amphenol Corporation		
RF/Microwave Operations Danbury, Conn. U.S.A.		
SCALENTS	SHEET	OF
ISSUE	A	

NOTICE - These drawings, specifications, or other data (1) are, and remain the property of Amphenol Corp (2) must be returned upon request; and (3) are confidential and are not to be disclosed to any person other than those to whom they are given by Amphenol Corp. The furnishing of these drawings, specifications, or other data by Amphenol Corp., or by any other person to anyone for any purpose is not to be regarded by implication or otherwise as in any manner licensing, granting rights or permitting such holder or any other person to manufacture, use or sell any product, process or design, patented or otherwise, that may in any way be related to or disclosed by said drawings, specifications or other data.