

ATLANTIC VERSION TERMINATOR INTERFACE ADAPTER	PART NUMBER	REVISION	DESCRIPTION	FEED TYPE	APPLICATOR STYLE CONVERSION CHART						
					CONVERT TO	PART NUMBERS REQUIRED					
	2150055-1	C	FINE CRIMP HEIGHT ADJUST	MECHANICAL	PNEUMATIC FEED	2119950-1	2119792-2	-	2119641-1	-	2063440-1
	2150055-2	C	FINE CRIMP HEIGHT ADJUST	PNEUMATIC	SERVO LATCH PLATE	2119951-1	1901697-1	8-2150055-5	-	-	2168400-7 (QUANTITY 2)
					SMART APPLICATOR	2161326-1	-	8-2150055-4	-	-	-
					MECHANICAL FEED	2119949-1	2063961-1	5-18022-5	2119653-1	-	-
	2150055-5	C	FINE CRIMP HEIGHT ADJUST	SERVO LATCH PLATE	SERVO LATCH PLATE	2119951-1	1901697-1	8-2150055-5	-	-	2168400-7 (QUANTITY 2)
					SMART APPLICATOR	2161326-1	-	8-2150055-4	-	-	-
					MECHANICAL FEED	2119949-1	2063961-1	5-18022-5	2119653-1	-	-
2150055-6	C	NON-CRIMP HEIGHT ADJUST	SERVO LATCH PLATE	PNEUMATIC FEED	2119950-1	2119792-2	-	2119641-1	-	2063440-1	
				-	-	-	-	-	-	-	
2150055-7	C	FINE CRIMP HEIGHT ADJUST	NONE	-	-	-	-	-	-	-	
7-2150055-7	A	CRIMP TOOLING KIT	-	-	-	-	-	-	-	-	

APPLICATOR DATA		
CRIMP	SIZE	TYPE
WIRE	2.54 mm [.100]	F
INSUL	5.33 mm [.210]	F
APPLICATOR INSTRUCTIONS 408-10390		

TERMINAL DATA: TE TERMINAL		TE CRIMP SPECIFICATION	
TERMINAL NAME: RECEPTACLE, FASTON, .187 SERIES			
WIRE STRIP LENGTH	INSULATION DIAMETER RANGE		
4.40-5.16 mm [.173-.203 IN]	Ø2.67-5.33 mm [.105-.210 IN]		
TERMINAL APPLICATION SPECIFICATION	114-2036		
TERMINALS APPLIED			
TE TERMINAL	TE TERMINAL	TE TERMINAL	TE TERMINAL
60487-1	61945-1	63470-1	1742899-1
60487-2	61945-2	63769-1	

WIRE SIZE	CRIMP HEIGHT mm [INCH]	CRIMP HEIGHT REFERENCE SETTING
(2)18 AWG	1.50+/-0.05 [.059+/-0.002]	8.0
(2)10.75mm2	1.42+/-0.05 [.056+/-0.002]	8.7
16 AWG	1.40+/-0.05 [.055+/-0.002]	9.0
(2)20 AWG	1.32+/-0.05 [.052+/-0.002]	9.5
18 AWG	1.25+/-0.05 [.049+/-0.002]	10.5

- RECOMMENDED SPARE PARTS
- GREASE BEARING SURFACES LIGHTLY
- LUBRICATE DAILY PER THE APPLICATOR INSTRUCTION SHEET SUPPLIED WITH THE APPLICATOR.
- APPLICATOR SPECIFIC DATA TO BE ENTERED INTO BLANK MEMORY CHIP AT ASSEMBLY. SEE BELOW FOR PART NUMBER:  
 MECHANICAL FEED WITH "SMART APPLICATOR" CONVERSION: 8-2150055-4  
 PNEUMATIC FEED WITH "SMART APPLICATOR" CONVERSION: 8-2150055-4  
 SERVO FEED WITH "FINE CRIMP HEIGHT ADJUST": 8-2150055-5  
 SERVO FEED WITH "NON-CRIMP HEIGHT ADJUST": 8-2150055-6
- ADJUSTMENT OF THE STRIPPER MAY BE REQUIRED WHEN MOVING THE APPLICATOR BETWEEN BENCH AND LEADMAKER APPLICATIONS.
- APPLY PART NUMBER 1-23419-5 LOCTITE TO THREADS OF ITEM 50 & 62. APPLY PART NUMBER 2-23419-6 LOCTITE TO THREADS OF ITEM 242. FOR -6 ONLY APPLY PART NUMBER 1-23419-5 LOCTITE TO THREADS OF ITEM 37.
- GREASE THREADS, GROOVE AND O-RING ON ITEMS 35 & 252.
- MAGNET, ITEM 166 MUST BE ORIENTED CORRECTLY IN ORDER TO PROPERLY ACTUATE THE COUNTER.
- CRIMP HEIGHT REFERENCE SETTING WAS THE SETTING USED WHEN THE APPLICATOR WAS QUALIFIED AT THE FACTORY. ADJUSTMENT MAY BE NECESSARY WHEN RUNNING APPLICATOR IN THE FIELD.
- SPARE FEED CAM STORAGE LOCATION REFER TO INSTRUCTION SHEET FOR ADDITIONAL INFORMATION.
- THE RECOMMENDED SET-UP FOR END FEED APPLICATORS IS POST-FEED WITH ITEM 2119653-1. THE APPLICATOR CAN BE CONFIGURED FOR PRE-FEED WITH ITEM 2119652-1 BUT MAY ENCOUNTER PROBLEMS WITH SOME APPLICATIONS. FEED ISSUES OR TERMINAL JAMMING MAY OCCUR IN THE PRE-FEED CONFIGURATION.
- WHEN ASSEMBLING -6 NON-CRIMP HEIGHT ADJUST APPLICATOR USE SHIM PACK 2119957-2 TO ALIGN APPLICATOR'S MAXIMUM WIRE CRIMP HEIGHT AT NORMAL TERMINATOR SHUT HEIGHT

**\*WARNING**  
 ON INSTALLATION, SET WIRE DISC, ITEM 40 TO LARGEST WIRE SIZE SETTING. USE OF SETTINGS BELOW MINIMUM REQUIRED CRIMP HEIGHT SETTING WILL CAUSE DAMAGE TO CRIMP TOOLING.

-77	-7	-6	-5	-2	-1	PART NO	DESCRIPTION	ITEM NO
-	-	1	-	-	-	2119957-2	APPLICATOR SHIM PACK	260
-	1	-	1	1	1	8-21084-0	O-RING, .676 ID, .070 DIA. MAT.	252
-	-	-	-	1	-	2119640-1	PUSH ROD, AIR FEED	250
-	-	-	-	1	-	2079988-1	BUSHING, LCH5-12, MISUMI	249
-	-	-	-	1	-	2119641-1	FEED CAM, AIR FEED	248
-	1	-	1	1	1	2119798-1	DETENT PIN	247
-	1	-	1	1	1	1-22279-3	SPRING, COMPRESSION	246
-	-	1	-	-	-	2119759-1	RAM, AMP STYLE, END FEED, NON-ADJUST	245

**ATLANTIC VERSION**  
 Shown on sheets 1 of 4 & 2 of 4  
 (Pacific version shown on sheets 3 of 4 & 4 of 4)

SET UP GAUGE	LOC	DIST	REVISIONS			
2119599-2	A	66	REV	DATE	BY	APPV
			B	ECR-13-007226	29APR2013	RK GB
			C	ECR-15-006875	04MAY2015	YY UT

-	1	1	1	1	1	2119082-9	CAM, SNAIL, INSULATION ADJUSTMENT	244
-	1	1	1	1	1	2079764-1	WASHER, WAVE SPRING, CREST-TO-CREST	243
-	1	1	1	1	1	2119083-1	RETAINER, INSULATION DIAL	242
-	-	2	2	-	-	2168400-7	SHCS, LOW HEAD, RoHS, M5 X 10	240
-	-	-	-	-	1	2119580-1	MECHANICAL FEED ASSEMBLY	239
-	-	-	-	1	-	2063440-1	AIR FEED MODULE	238
-	-	1	1	-	-	2119740-2	TAG, IDENTIFICATION	213
-	-	REFREF	-	-	-	1901697-1	FEED FINGER ASSEMBLY, EF	183
-	1	1	1	1	1	6-993111-6	PIN, SLOTTED SPRING 3.0 X 14.0	177
-	1	1	1	1	1	8-22280-7	SPRING, COMPRESSION	176
-	1	1	1	1	1	1752353-2	GUIDE PIN, HOLDDOWN	175
-	1	1	1	1	1	1901680-2	GUIDE PIN, HOLDDOWN	174
-	-	-	-	2	-	21045-3	RING, RETAIN, EXTERN, 3/16 CRESCENT	172
-	1	1	1	1	1	994969-1	MAGNET, RARE EARTH HIGH ENERGY	166
-	REFREF	REFREF	REFREF	REFREF	REFREF	994970-2	COUNTER, MAGNETIC	164
-	-	-	-	1	-	240638-1	SPRING, FEED FINGER	163
-	-	-	-	1	-	3-23627-7	PIN, RETAIN, GRVD, 3/16 X .854	137
-	-	REFREF	-	-	-	SEE NOTE 4	MEMORY CHIP, PROGRAMMED	135
-	-	1	1	-	-	1633743-1	SERVO FEED LATCH ASM	133
-	1	1	1	1	1	2119955-2	ASSY, LUBRICATOR, END FEED	84
-	1	1	1	1	1	455888-8	SPACER, CRIMPER	82
-	1	1	1	1	1	2119956-2	DOCUMENTATION PACKAGE	71
-	2	2	2	2	2	2-18032-2	SCR, SET, FLT POINT M3 X 10.0	70
-	1	-	-	1	1	2119740-1	TAG, IDENTIFICATION	67
-	2	2	2	2	2	2168078-1	SCREW, DRIVE, RH, RoHS, 2 x .188	66
-	1	1	1	1	1	1-1901681-8	HOLDDOWN, TERMINAL	65
-	2	2	2	2	2	2168400-5	SHCS, LOW HEAD, RoHS, M4 X 20	64
-	1	-	1	1	1	2119793-1	LIMITER, ADJUSTMENT BOLT	63
-	3	-	3	3	3	992763-5	SCR, SET, SOC, CONE POINT, M3 X 4.0	62
-	1	1	1	1	1	2079383-4	SCR, BHSC, RoHS (M4 X 8)	60
-	-	-	-	-	1	5-18022-5	SCR, HEX HD CAP, M4 X 6.0	59
-	-	-	-	-	1	2063961-1	FEED FINGER	58
-	3	3	3	3	3	2168400-4	SHCS, LOW HEAD, RoHS, M4 X 8	57
-	2	2	2	2	2	2168083-2	SCR, SKT HD CAP, RoHS, M4 X 8.0	56
-	2	2	2	2	2	5018030-2	NUT, HEX, REG, RoHS, M4	55
-	2	2	2	2	2	5018030-1	NUT, HEX, REG, RoHS, M3	54
-	2	2	2	2	2	986965-8	NUT, LOCK, HEX, TORQUE (M4)	53
-	1	1	1	1	1	1-5018030-0	NUT, HEX, REG, RoHS, M3.5	52
-	-	-	-	1	-	2119792-2	PAWL, EF, AIR	51
-	1	1	1	1	1	1752354-7	STANDOFF, HOLD-DOWN	50
-	-	-	-	1	2	18023-9	SCR, SKT HD CAP M4 X 6.0	49
-	-	-	-	-	1	2119652-1	FEED CAM, PRE FEED	48
-	-	-	-	-	1	2119653-1	FEED CAM, POST FEED	47
-	1	1	1	1	1	2119655-5	APPLICATOR BASIC ASSEMBLY, EF	46
-	1	-	1	1	1	2119369-1	RAM, AMP STYLE, END FEED	44
-	1	1	1	1	1	2079383-7	SCR, BHSC, RoHS (M8 X 25)	41
-	1	-	1	1	1	2119645-1	DISC, NUMBERED FA WIRE ADJUSTMENT	40
-	1	-	1	1	1	2119957-1	APPLICATOR SHIM PACK	39
-	1	1	1	1	1	1-2119644-2	RAM WASHER, PRECISION	38
-	1	1	1	1	1	2119085-1	FA HEAD, ATLANTIC STYLE	37
-	1	-	1	1	1	2119092-1	BOLT, ADJUSTMENT	35
-	7	7	7	7	7	1-18028-2	WASHER, FLAT, REG M4	33
-	2	2	2	2	2	2168083-9	SCR, SKT HD CAP, RoHS, M4 X 20	31
-	2	2	2	2	2	1-2168083-0	SCR, SKT HD CAP, RoHS, M4 X 10	29
-	1	1	1	1	1	240639-4	STRIPPER (MACHINING)	27
-	2	2	2	2	2	1320906-1	STUD, THREADED	25
-	1	1	1	1	1	1752371-1	PLATE, STRIP GUIDE	24
-	1	1	1	1	1	240825-8	PLATE, STRIP HOLD DOWN	23
-	2	2	2	2	2	2-22281-3	SPRING, COMPRESSION	22
-	1	1	1	1	1	1752373-1	DRAG	20
-	2	2	2	2	2	1901259-4	GUIDE, LOWER STRIP	18
-	4	4	4	4	4	1-2079383-1	SCR, BHSC, RoHS (M6 X 12)	17
-	1	1	1	1	1	1752360-1	SPACER, HOLD-DOWN	13
-	1	1	1	1	1	240644-1	PLATE, REAR SHEAR	11
-	-	-	-	-	-	-	-	10
-	1	1	1	1	1	690482-6	PLATE, FRONT SHEAR	9
-	1	1	1	1	1	1-1333218-3	ANVIL, COMBINATION	8
-	1	1	1	1	1	690474-6	BLADE, SLUG	7
-	1	1	1	1	1	240641-7	SPACER	5
-	1	1	1	1	1	238009-1	BLOCK, FL CRIMPER SPACER	4
-	1	1	1	1	1	1633961-1	CRIMPER, INSULATION F PREMIUM	3
-	1	1	1	1	1	455888-5	SPACER, CRIMPER	2
-	1	1	1	1	1	456407-3	CRIMPER, WIRE PREMIUM	1

DIMENSIONS:	TOLERANCES UNLESS OTHERWISE SPECIFIED:	DATE	BY	APPV	NAME
mm	0 PLC ±.5 1 PLC ±.5 2 PLC ±.5 3 PLC ±.5 4 PLC ±.5 ANGLES ±.0001	02FEB2012	L. ZHANG	L. ZHANG	TE Connectivity Harrisburg, PA 17105-3608
		02FEB2012	S. XI	S. XI	Ocean End Feed Applicator
MATERIAL:	FINISH:	WEIGHT:	SIZE	CAGE CODE	DRAWING NO
			A1	00779	©=2150055
Customer Accessible Production Drawing		SCALE	SHEET	1	OF 4
		REV	C		

LOC		DIST		REVISIONS			
A	66	P	LTM	DESCRIPTION	DATE	OWN	APVD
		-		SEE SHEET 1			

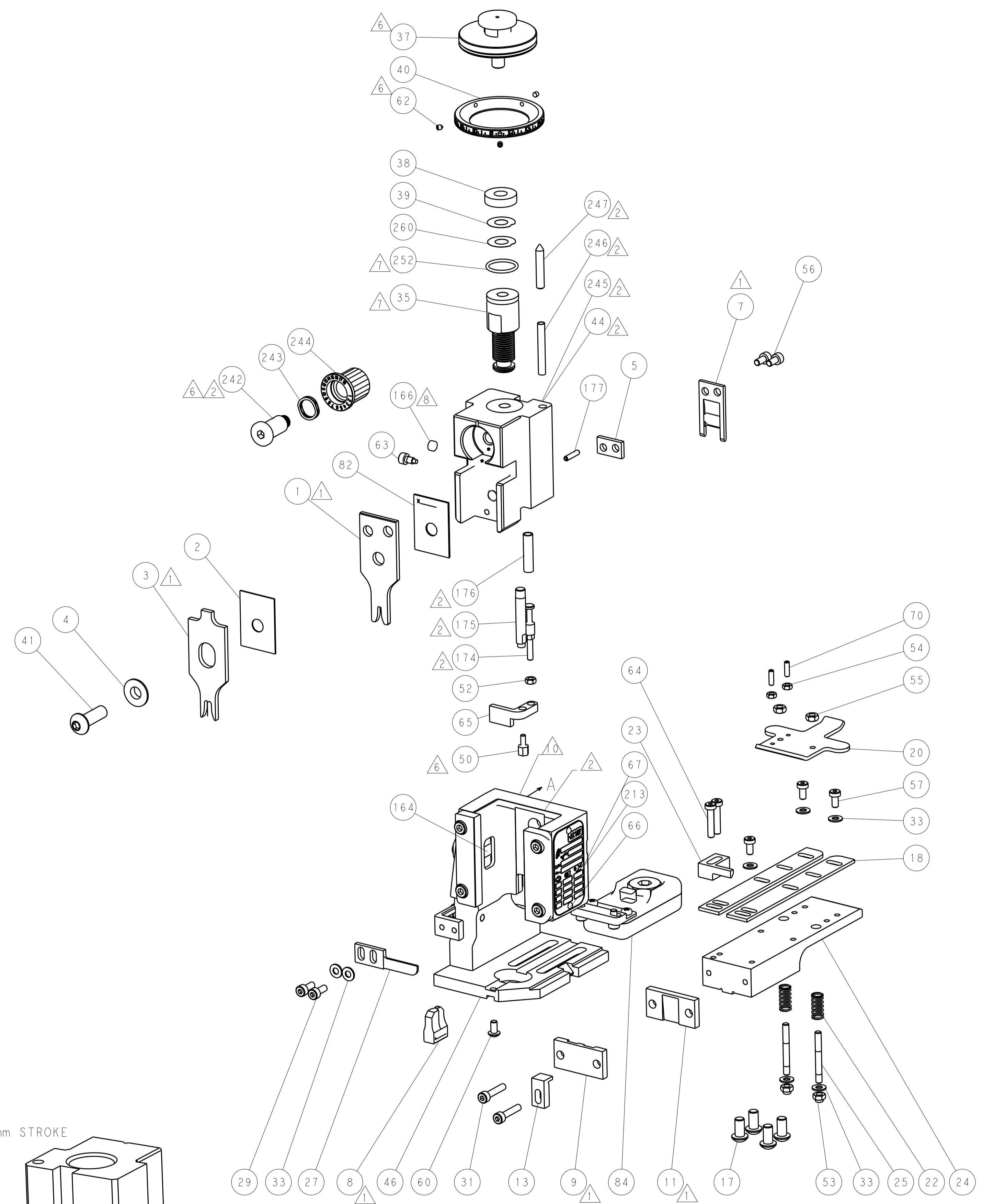
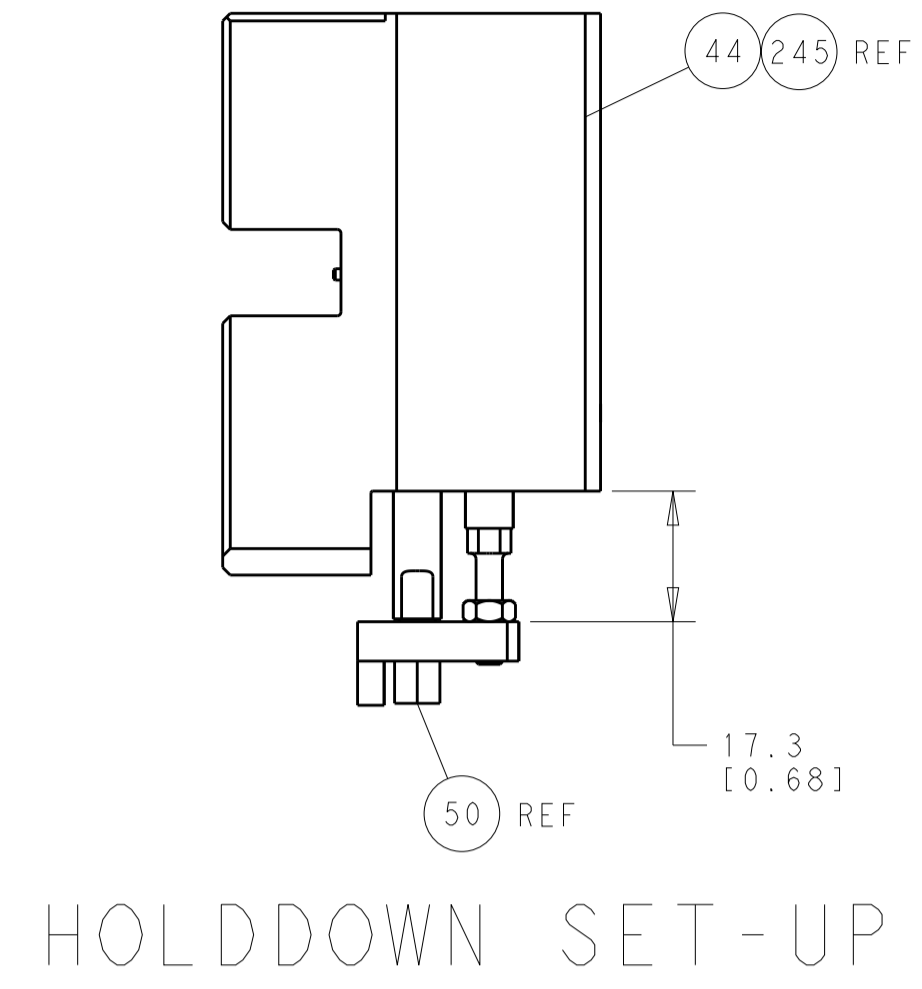

FEED TYPE  
MECHANICAL

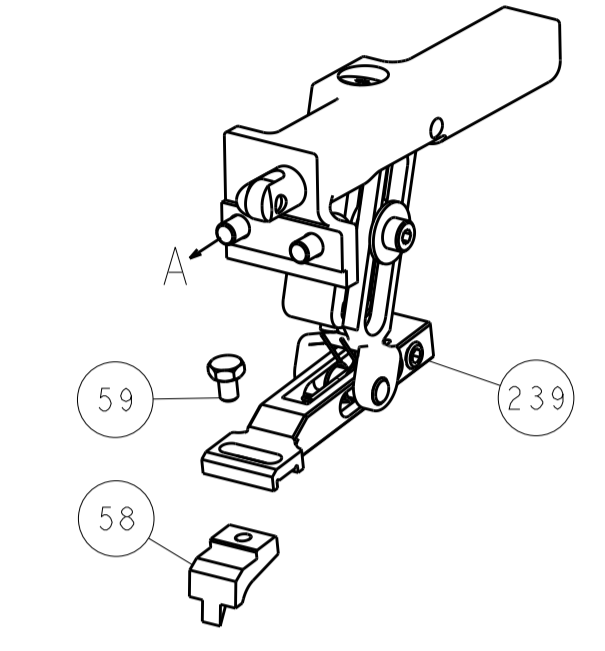

PNEUMATIC

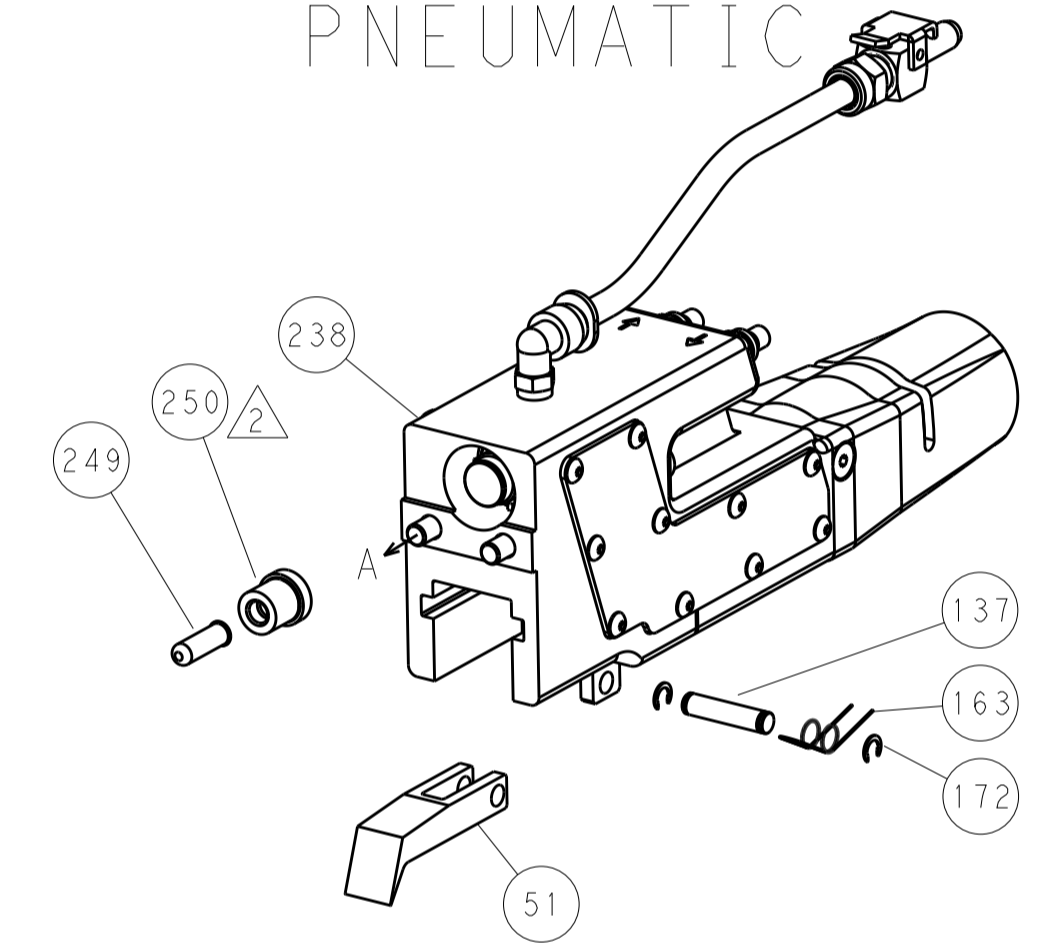

SERVO  
LATCH PLATE

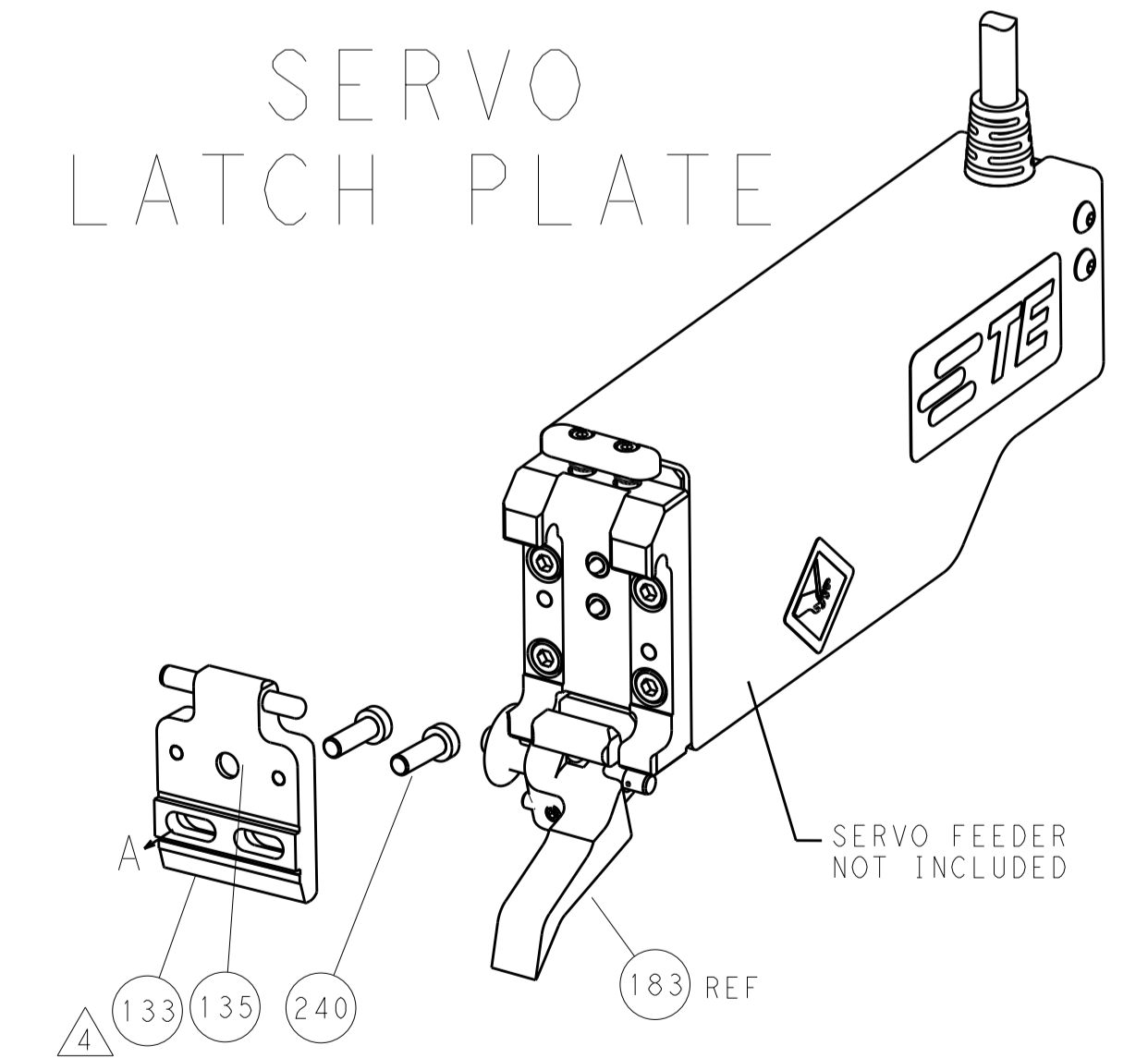

CAM POSITIONS

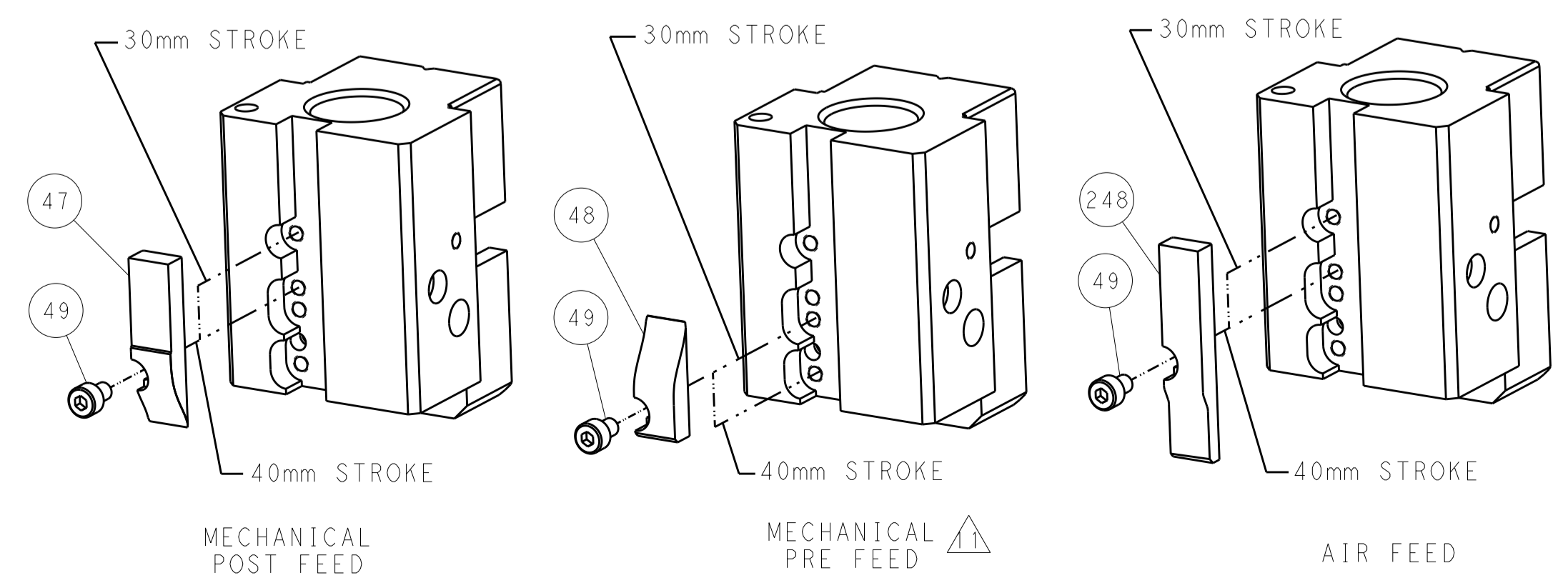

ATLANTIC VERSION  
 Shown on sheets 1 of 4 & 2 of 4  
 (Pacific version shown on sheets 3 of 4 & 4 of 4)

DIMENSIONS:		TOLERANCES UNLESS OTHERWISE SPECIFIED:		DWG: L. ZHANG 02FEB2012		TE Connectivity	
mm	0 PLC ±0.5	1 PLC ±0.5	2 PLC ±0.13	3 PLC ±0.13	4 PLC ±0.001	APVD: S. XI 02FEB2012	Harrisburg, PA 17105-3608
MATERIAL:		FINISH:		NAME: Ocean End Feed Applicator		RESTRICTED TO:	
				SIZE: A1		CAGE CODE: 00779	
				DRAWING NO: C-2150055		SCALE: 1:1	
				SHEET: 2 of 4		REV: C	



LOC	DIST	REV	DATE	BY	APPV
A	66				

REVISIONS			
NO.	DESCRIPTION	DATE	BY
1	SEE SHEET 1		

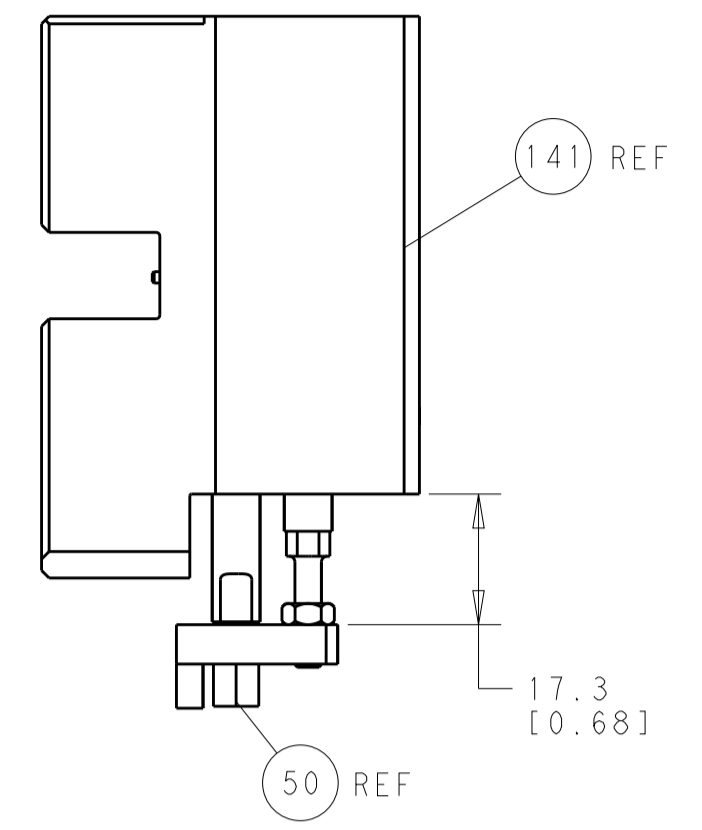

HOLDDOWN SET-UP

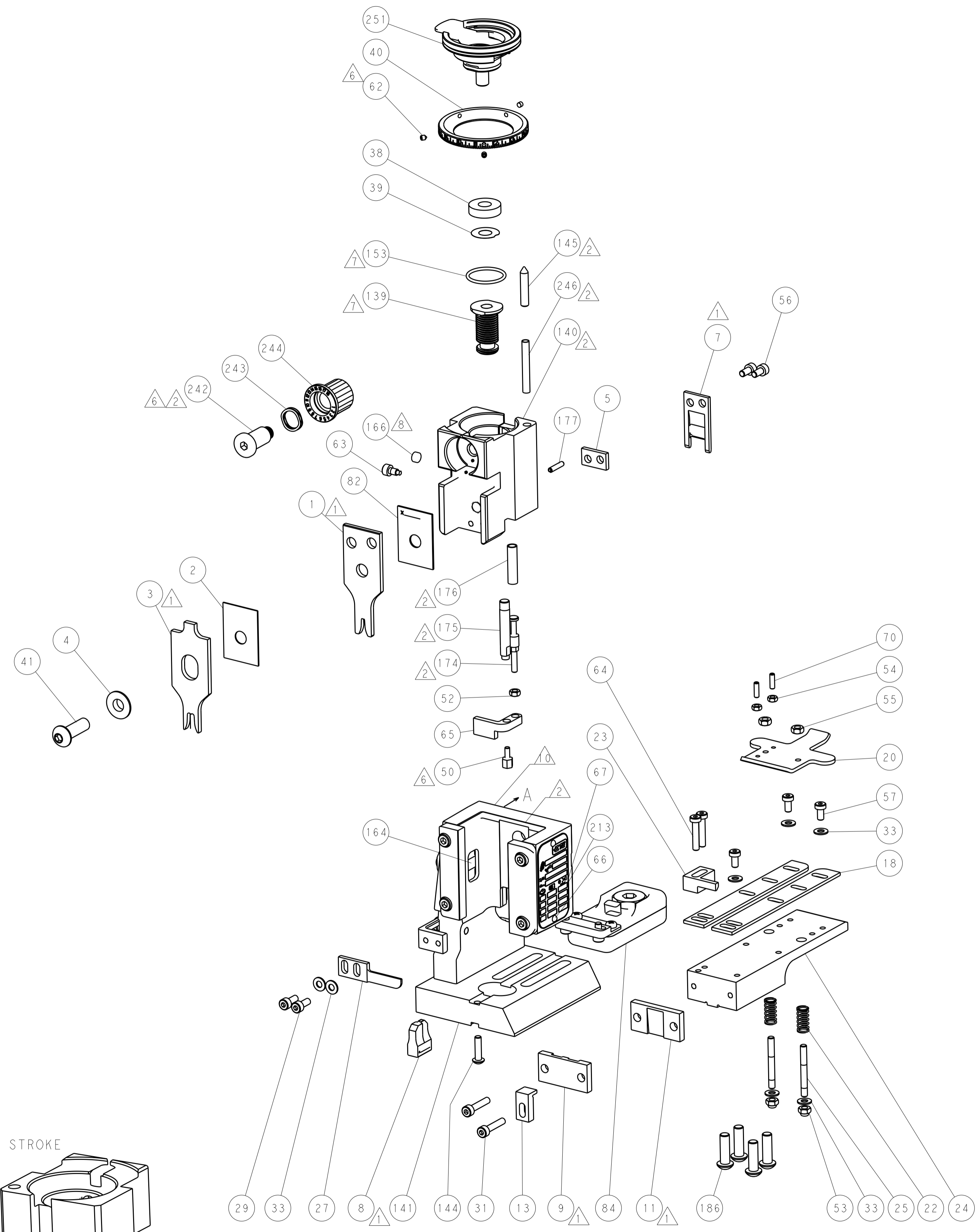

FEED TYPE  
MECHANICAL

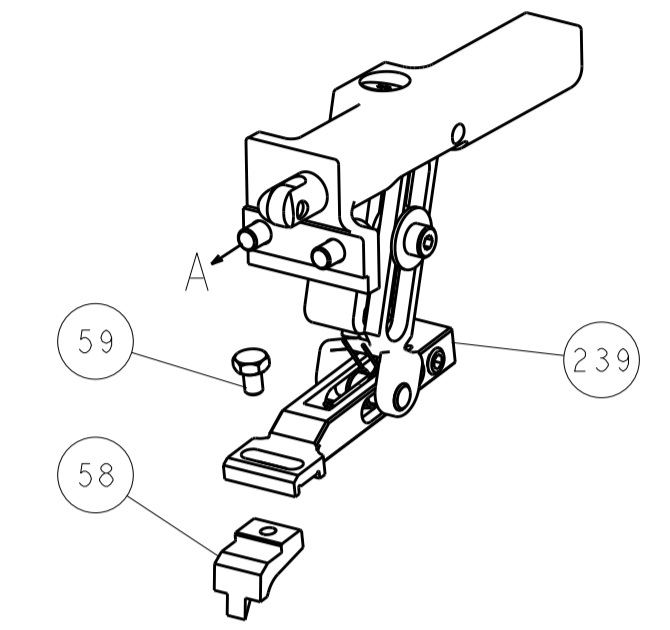

PNEUMATIC

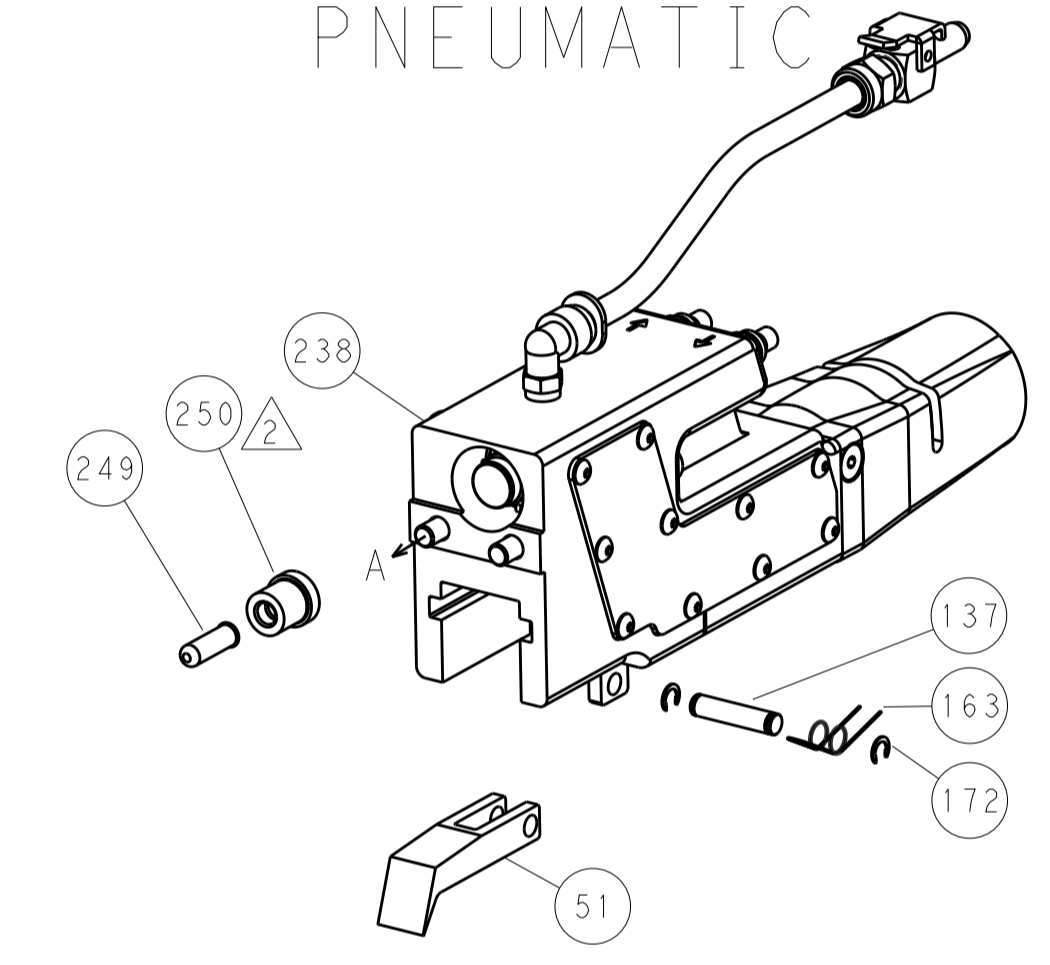

SERVO  
LATCH PLATE

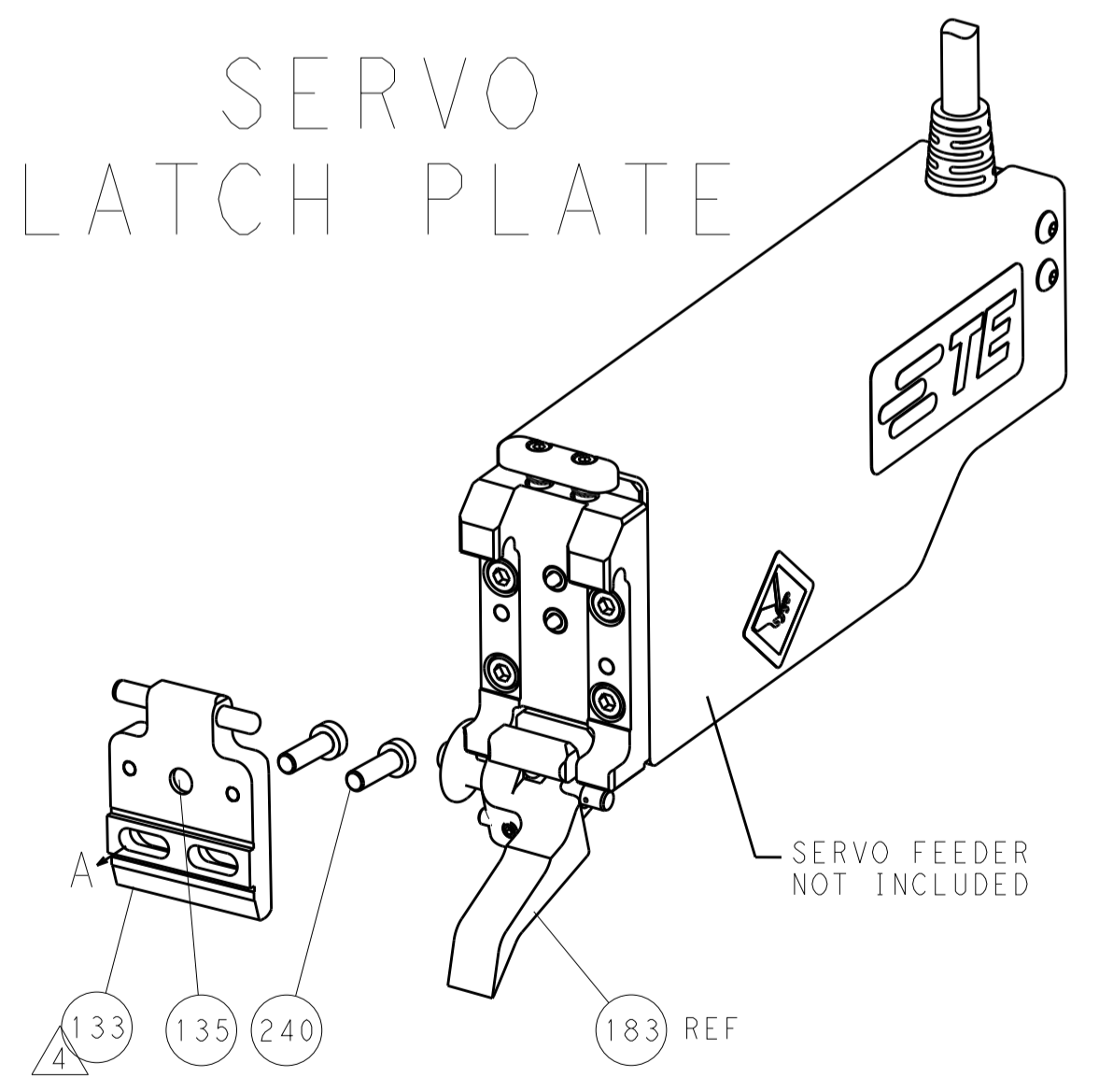

CAM POSITIONS

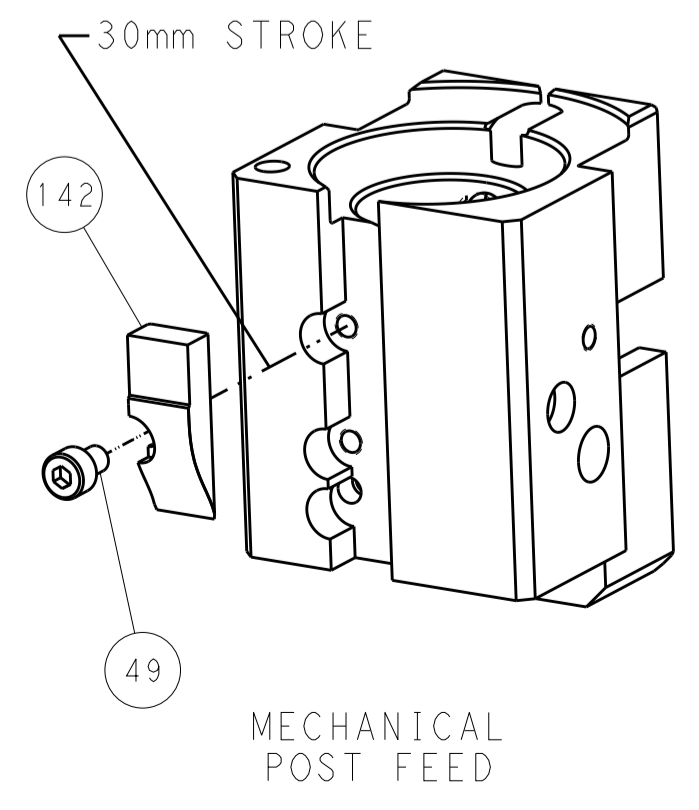

MECHANICAL  
POST FEED

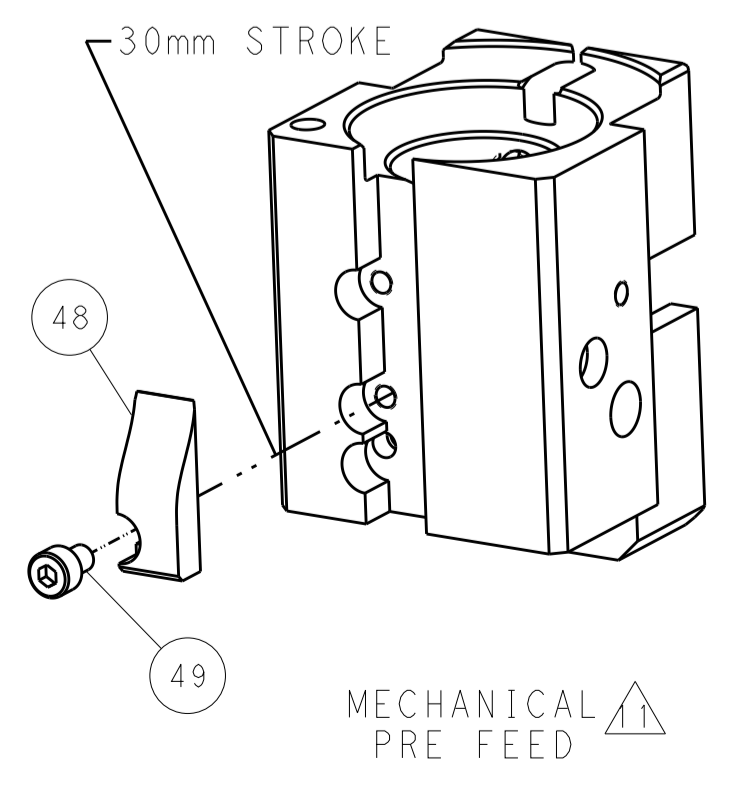

MECHANICAL  
PRE FEED

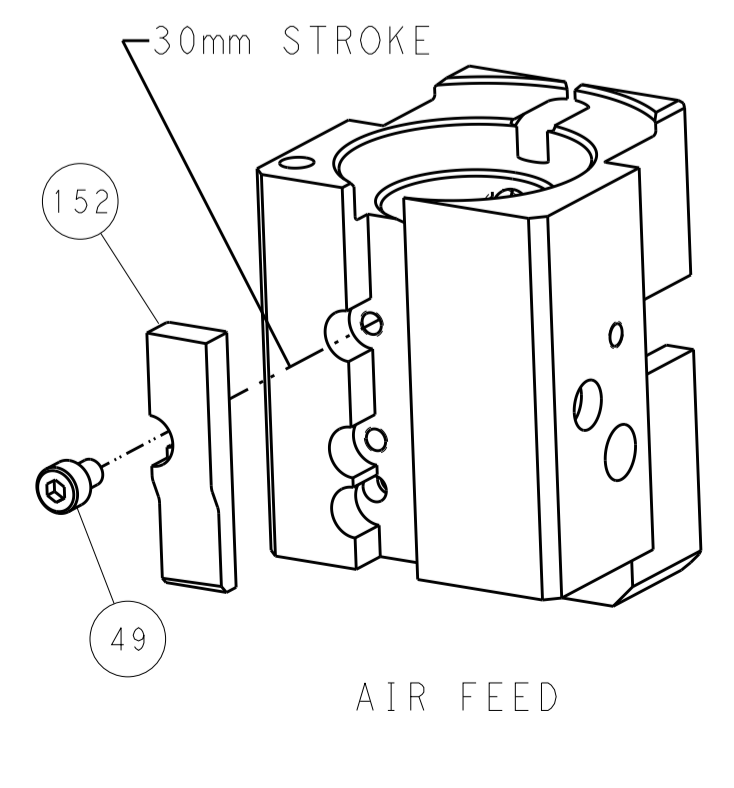

AIR FEED

**PACIFIC VERSION**  
 Shown on sheets 3 of 4 & 4 of 4  
 (Atlantic version shown on sheets 1 of 4 & 2 of 4)

DIMENSIONS:		TOLERANCES UNLESS OTHERWISE SPECIFIED:		DWG: L. ZHANG 02FEB2012		CHK: L. ZHANG 02FEB2012		NAME: Ocean End Feed Applier	
mm	0 PLC ±0.5	1 PLC ±0.13	3 PLC ±0.013	4 PLC ±0.001	ANGLES ±0.001	PRODUCT SPEC	APPLICATION SPEC	SIZE: A1	CAGE CODE: 00779
MATERIAL:	FINISH:	WEIGHT:	SCALE: 1:1	SHEET: 4	OF: 4	REV: C	Customer Accessible Production Drawing		