

| ATLANTIC VERSION TERMINATOR INTERFACE ADAPTER | PART NUMBER | REVISION                 | DESCRIPTION              | FEED TYPE         | APPLICATOR STYLE CONVERSION CHART |                       |           |             |           |           |                        |
|---|-------------|--------------------------|--------------------------|-------------------|-----------------------------------|-----------------------|-----------|-------------|-----------|-----------|------------------------|
|   |             |                          |                          |                   | CONVERT TO                        | PART NUMBERS REQUIRED |           |             |           |           |                        |
|   | 2151353-1   | H                        | FINE CRIMP HEIGHT ADJUST | MECHANICAL        | PNEUMATIC FEED                    | 2119950-1             | 1338685-1 | 5-18022-5   | 2119641-1 | 2119799-1 | 2063440-1              |
|   | 2151353-2   | H                        | FINE CRIMP HEIGHT ADJUST | PNEUMATIC         | SERVO LATCH PLATE                 | 2119951-1             | 2119944-1 | 8-2151353-5 | 1901094-3 | 1976043-1 | 2168400-6 (QUANTITY 2) |
|   |             |                          |                          |                   | SMART APPLICATOR                  | 2161326-1             | -         | 8-2151353-4 | -         | -         | -                      |
|   |             |                          |                          |                   | MECHANICAL FEED                   | 2119949-1             | 1338685-1 | 5-18022-5   | 2119653-1 | -         | -                      |
|   | 2151353-5   | H                        | FINE CRIMP HEIGHT ADJUST | SERVO LATCH PLATE | SERVO LATCH PLATE                 | 2119951-1             | 2119944-1 | 8-2151353-5 | 1901094-3 | 1976043-1 | 2168400-6 (QUANTITY 2) |
|   |             |                          |                          |                   | SMART APPLICATOR                  | 2161326-1             | -         | 8-2151353-4 | -         | -         | -                      |
|   | 2151353-6   | H                        | NON-CRIMP HEIGHT ADJUST  | SERVO LATCH PLATE | MECHANICAL FEED                   | 2119949-1             | 1338685-1 | 5-18022-5   | 2119653-1 | -         | -                      |
| PNEUMATIC FEED                                |             |                          |                          |                   | 2119950-1                         | 1338685-1             | 5-18022-5 | 2119641-1   | 2119799-1 | 2063440-1 |                        |
| 2151353-7                                     | H           | FINE CRIMP HEIGHT ADJUST | NONE                     | -                 | -                                 | -                     | -         | -           | -         | -         |                        |
| 7-2151353-7                                   | A           | CRIMP TOOLING KIT        | -                        | -                 | -                                 | -                     | -         | -           | -         | -         |                        |

| APPLICATOR DATA |                |      |
|-----------------|----------------|------|
| CRIMP           | SIZE           | TYPE |
| WIRE            | 1.78 mm [.070] | F    |
| INSUL           | 2.29 mm [.090] | BX   |

APPLICATOR INSTRUCTIONS 408-10389

| TERMINAL DATA: TE TERMINAL         |             | TE CRIMP SPECIFICATION       |             |
|------------------------------------|-------------|------------------------------|-------------|
| TERMINAL NAME: MCON 1.2 LL         |             |                              |             |
| WIRE STRIP LENGTH                  |             | INSULATION DIAMETER RANGE    |             |
| 3.30-3.90 mm [.130-.154 IN]        |             | Ø1.90-2.40 mm [.075-.094 IN] |             |
| TERMINAL APPLICATION SPECIFICATION | 114-18464   | -                            | -           |
| TERMINALS APPLIED                  |             |                              |             |
| TE TERMINAL                        | TE TERMINAL | TE TERMINAL                  | TE TERMINAL |
| 1452659-1                          | 1452659-2   | 1452659-3                    |             |
| 7-1452659-1                        | 7-1452659-2 | 7-1452659-3                  |             |

| WIRE SIZE | CRIMP HEIGHT mm [INCH]     | CRIMP HEIGHT REFERENCE SETTING |
|-----------|----------------------------|--------------------------------|
| 1.50mm2   | 1.31+/-0.05 [.052+/-0.002] | 8.0                            |
| 16 AWG    | 1.26+/-0.05 [.050+/-0.002] | 8.5                            |
| 1.00mm2   | 1.10+/-0.05 [.043+/-0.002] | 10.0                           |
| 18 AWG    | 1.05+/-0.05 [.041+/-0.002] | 10.6                           |

- 1 RECOMMENDED SPARE PARTS
- 2 GREASE BEARING SURFACES LIGHTLY
- 3. LUBRICATE DAILY PER THE APPLICATOR INSTRUCTION SHEET SUPPLIED WITH THE APPLICATOR.
- 4 APPLICATOR SPECIFIC DATA TO BE ENTERED INTO BLANK MEMORY CHIP AT ASSEMBLY. SEE BELOW FOR PART NUMBER:  
 MECHANICAL FEED WITH "SMART APPLICATOR" CONVERSION: 8-2151353-4  
 PNEUMATIC FEED WITH "SMART APPLICATOR" CONVERSION: 8-2151353-4  
 SERVO FEED WITH "FINE CRIMP HEIGHT ADJUST": 8-2151353-5  
 SERVO FEED WITH "NON-CRIMP HEIGHT ADJUST": 8-2151353-6
- 5. ADJUSTMENT OF THE STRIPPER MAY BE REQUIRED WHEN MOVING THE APPLICATOR BETWEEN BENCH AND LEADMAKER APPLICATIONS.
- 6 APPLY PART NUMBER 1-23419-5 LOCTITE TO THREADS OF ITEM 62. APPLY PART NUMBER 2-23419-6 LOCTITE TO THREADS OF ITEM 242. FOR -6 ONLY APPLY PART NUMBER 1-23419-5 LOCTITE TO THREADS OF ITEM 37.
- 7 GREASE THREADS, GROOVE AND O-RING ON ITEMS 35 & 252.
- 8 MAGNET, ITEM 166 MUST BE ORIENTED CORRECTLY IN ORDER TO PROPERLY ACTUATE THE COUNTER.
- 9 CRIMP HEIGHT REFERENCE SETTING WAS THE SETTING USED WHEN THE APPLICATOR WAS QUALIFIED AT THE FACTORY. ADJUSTMENT MAY BE NECESSARY WHEN RUNNING APPLICATOR IN THE FIELD.
- 10 SPARE FEED CAM STORAGE LOCATION REFER TO INSTRUCTION SHEET FOR ADDITIONAL INFORMATION.
- 11 TO CONVERT THE APPLICATOR TO A NON-CARRIER CUTTING STYLE, REMOVE ITEM 13 AND ATTACH TO THE LOCATION ON THE BACK SIDE OF THE HOUSING. REFER TO INSTRUCTION SHEET FOR ADDITIONAL INFORMATION.
- 12 WHEN ASSEMBLING -6 NON-CRIMP HEIGHT ADJUST APPLICATOR USE SHIM PACK 2119957-2 TO ALIGN APPLICATOR'S MAXIMUM WIRE CRIMP HEIGHT AT NORMAL TERMINATOR SHUT HEIGHT
- 13 TERMINAL LUBRICANT IS RECOMMENDED.

**\*WARNING**  
 ON INSTALLATION, SET WIRE DISC, ITEM 40 TO LARGEST WIRE SIZE SETTING. USE OF SETTINGS BELOW MINIMUM REQUIRED CRIMP HEIGHT SETTING WILL CAUSE DAMAGE TO CRIMP TOOLING.

|     |    |    |    |    |    |           |                                 |         |
|-----|----|----|----|----|----|-----------|---------------------------------|---------|
| -   | -  | 1  | -  | -  | -  | 2119957-2 | APPLICATOR SHIM PACK            | 260     |
| -   | 1  | -  | 1  | 1  | 1  | 8-21084-0 | O-RING, .676 ID, .070 DIA. MAT. | 252     |
| -   | -  | -  | -  | 1  | -  | 2119640-1 | PUSH ROD, AIR FEED              | 250     |
| -77 | -7 | -6 | -5 | -2 | -1 | PART NO   | DESCRIPTION                     | ITEM NO |

**ATLANTIC VERSION**  
 Shown on sheets 1 of 4 & 2 of 4  
 (Pacific version shown on sheets 3 of 4 & 4 of 4)

| SET UP GAUGE | LOC | DIST | REVISIONS |     |               |           |     |      |
|--------------|-----|------|-----------|-----|---------------|-----------|-----|------|
| 2119599-1    | A   | 66   | P         | LTN | DESCRIPTION   | DATE      | OWN | APVD |
|              |     |      | E         |     | ECR-15-012530 | 09SEP2015 | MR  | CT   |
|              |     |      | F         |     | ECR-15-014230 | 28SEP2015 | JH  | TE   |
|              |     |      | G         |     | ECR-15-014766 | 10OCT2015 | JH  | TE   |
|              |     |      | H         |     | ECR-17-005581 | 18APR2017 | TB  | TE   |

|     |     |     |     |     |     |             |                                     |         |
|-----|-----|-----|-----|-----|-----|-------------|-------------------------------------|---------|
| -   | -   | -   | -   | 1   | -   | 1803259-1   | BUSHING, FLANGED                    | 249     |
| -   | -   | -   | -   | 1   | -   | 2119641-1   | FEED CAM, AIR FEED                  | 248     |
| -   | 1   | -   | 1   | 1   | 1   | 2119798-1   | DETENT PIN                          | 247     |
| -   | 1   | -   | 1   | 1   | 1   | 1-22279-3   | SPRING, COMPRESSION                 | 246     |
| -   | -   | 1   | -   | -   | -   | 2119758-1   | RAM, AMP STYLE, SIDE FEED, NON-ADJ. | 245     |
| -   | 1   | 1   | 1   | 1   | 1   | 2119082-4   | CAM, SNAIL, INSULATION ADJUSTMENT   | 244     |
| -   | 1   | 1   | 1   | 1   | 1   | 2079764-1   | WASHER, WAVE SPRING, CREST-TO-CREST | 243     |
| -   | 1   | 1   | 1   | 1   | 1   | 2119083-1   | RETAINER, INSULATION DIAL           | 242     |
| -   | 1   | 1   | 1   | 1   | 1   | 7-18023-7   | SCR, SKT HD CAP M3 X 4.0            | 241     |
| -   | -   | 2   | 2   | -   | -   | 2168400-6   | SHCS, LOW HEAD, RoHS, M5 X 16       | 240     |
| -   | -   | -   | -   | -   | 1   | 2119580-1   | MECHANICAL FEED ASSEMBLY            | 239     |
| -   | -   | -   | -   | 1   | -   | 2063440-1   | AIR FEED MODULE                     | 238     |
| -   | -   | 1   | 1   | -   | -   | 2119740-2   | TAG, IDENTIFICATION                 | 213     |
| -   | -   | 1   | 1   | -   | -   | 1901094-3   | SPACER, FEEDER                      | 198     |
| -   | -   | -   | -   | 2   | -   | 21045-3     | RING, RETAIN, EXTERN, 3/16 CRESCENT | 172     |
| -   | 1   | 1   | 1   | 1   | 1   | 994969-1    | MAGNET, RARE EARTH HIGH ENERGY      | 166     |
| -   | REF | REF | REF | REF | REF | 994970-2    | COUNTER, MAGNETIC                   | 164     |
| -   | -   | -   | -   | 1   | -   | 240638-1    | SPRING, FEED FINGER                 | 163     |
| -   | -   | -   | -   | 1   | -   | 3-23627-7   | PIN, RETAIN, GRVD, 3/16 X .854      | 137     |
| -   | -   | -   | -   | 1   | -   | 2119799-1   | HOLDER, FEED FINGER, AF             | 136     |
| -   | -   | REF | REF | -   | -   | SEE NOTE 4  | MEMORY CHIP, PROGRAMMED             | 135     |
| -   | -   | 1   | 1   | -   | -   | 1633743-1   | SERVO FEED LATCH ASM                | 133     |
| -   | 1   | 1   | 1   | 1   | 1   | 1-18028-2   | WASHER, FLAT, REG M4                | 119     |
| -   | -   | REF | REF | -   | -   | 2119944-1   | FEED FINGER ASSEMBLY, SF            | 117     |
| -   | 1   | 1   | 1   | 1   | 1   | 2119955-1   | ASSY, LUBRICATOR, SIDE FEED         | 113     |
| -   | 1   | 1   | 1   | 1   | 1   | 455888-5    | SPACER, CRIMPER                     | 82      |
| -   | 1   | 1   | 1   | 1   | 1   | 22278-8     | SPRING, COMPRESSION                 | 77      |
| -   | 1   | 1   | 1   | 1   | 1   | 854769-4    | HOLDER, INS                         | 74      |
| -   | 1   | 1   | 1   | 1   | 1   | 2119956-1   | DOCUMENTATION PACKAGE               | 71      |
| -   | 1   | -   | -   | 1   | 1   | 2119740-1   | TAG, IDENTIFICATION                 | 67      |
| -   | 2   | 2   | 2   | 2   | 2   | 2168078-1   | SCREW, DRIVE, RH, RoHS, 2 x .188    | 66      |
| -   | 1   | -   | 1   | 1   | 1   | 2119793-1   | LIMITER, ADJUSTMENT BOLT            | 63      |
| -   | 3   | -   | 3   | 3   | 3   | 992763-5    | SCR, SET, SOC, CONE POINT, M3 X 4.0 | 62      |
| -   | 1   | 1   | 1   | 1   | 1   | 2079383-4   | SCR, BHSC, RoHS (M4 X 8)            | 60      |
| -   | -   | -   | -   | 1   | 1   | 5-18022-5   | SCR, HEX HD CAP, M4 X 6.0           | 59      |
| -   | 1   | 1   | 1   | 1   | 1   | 21028-2     | PIN, SLOTTED SPRING .062 X .250     | 58      |
| -   | -   | -   | -   | 1   | 1   | 1338685-1   | PAWL, FEED                          | 56      |
| -   | 4   | 4   | 4   | 4   | 4   | 2168400-1   | SHCS, LOW HEAD, RoHS, M4 X 12       | 54      |
| -   | 2   | 2   | 2   | 2   | 2   | 1-2168083-0 | SCR, SKT HD CAP, RoHS, M4 X 10      | 53      |
| -   | -   | -   | -   | 1   | 2   | 18023-9     | SCR, SKT HD CAP M4 X 6.0            | 49      |
| -   | -   | -   | -   | -   | 1   | 2119652-1   | FEED CAM, PRE FEED                  | 48      |
| -   | -   | -   | -   | -   | 1   | 2119653-1   | FEED CAM, POST FEED                 | 47      |
| -   | 1   | 1   | 1   | 1   | 1   | 2119656-9   | APPLICATOR BASIC ASSEMBLY, SF       | 46      |
| -   | 1   | -   | 1   | 1   | 1   | 2119370-1   | RAM, AMP STYLE, SIDE FEED           | 44      |
| -   | 1   | 1   | 1   | 1   | 1   | 2079383-7   | SCR, BHSC, RoHS (M8 X 25)           | 41      |
| -   | 1   | -   | 1   | 1   | 1   | 2119645-1   | DISC, NUMBERED FA WIRE ADJUSTMENT   | 40      |
| -   | 1   | -   | 1   | 1   | 1   | 2119957-1   | APPLICATOR SHIM PACK                | 39      |
| -   | 1   | 1   | 1   | 1   | 1   | 1-2119644-2 | RAM WASHER, PRECISION               | 38      |
| -   | 1   | 1   | 1   | 1   | 1   | 2119085-1   | FA HEAD, ATLANTIC STYLE             | 37      |
| -   | 1   | -   | 1   | 1   | 1   | 2119092-1   | BOLT, ADJUSTMENT                    | 35      |
| -   | 1   | 1   | 1   | 1   | 1   | 1752356-6   | SUPPORT, TERMINAL                   | 34      |
| -   | 2   | 2   | 2   | 2   | 2   | 2079383-5   | SCR, BHSC, RoHS (M4 X 20)           | 33      |
| -   | 1   | 1   | 1   | 1   | 1   | 2161328-1   | HEX HEAD, FLANGED, M5 X 8mm LONG    | 32      |
| -   | 1   | 1   | 1   | 1   | 1   | 1320908-3   | SPACER, STRIP GUIDE                 | 30      |
| -   | 1   | 1   | 1   | 1   | 1   | 2119959-2   | ASSEMBLY, STRIP GUIDE               | 29      |
| -   | 1   | 1   | 1   | 1   | 1   | 455888-4    | SPACER, CRIMPER                     | 28      |
| -   | 1   | 1   | 1   | 1   | 1   | 1320928-2   | STRIP GUIDE                         | 24      |
| -   | 1   | 1   | 1   | 1   | 1   | 2168083-2   | SCR, SKT HD CAP, RoHS, M4 X 8.0     | 21      |
| -   | 3   | 3   | 3   | 3   | 3   | 1-18028-2   | WASHER, FLAT, REG M4                | 20      |
| -   | 1   | 1   | 1   | 1   | 1   | 2119533-1   | STRIPPER, SIDE FEED                 | 19      |
| -   | 1   | 1   | 1   | 1   | 1   | 1333264-1   | HOLD DOWN                           | 18      |
| -   | 1   | 1   | 1   | 1   | 1   | 2119806-1   | INSERT, SHEAR                       | 13      |
| -   | 1   | 1   | 1   | 1   | 1   | 3-22280-3   | SPRING, COMPRESSION                 | 12      |
| -   | 1   | 1   | 1   | 1   | 1   | 1-356885-4  | STOP, SHEAR                         | 11      |
| -   | 1   | 1   | 1   | 1   | 1   | 2119805-1   | SHEAR HOLDER, FRONT                 | 10      |
| -   | 1   | 1   | 1   | 1   | 1   | 1633861-1   | SHEAR, FLOATING                     | 9       |
| -   | 1   | 1   | 1   | 1   | 1   | 4-1333203-2 | ANVIL, COMBINATION                  | 8       |
| -   | -   | -   | -   | -   | -   | -           | -                                   | 7       |
| -   | -   | -   | -   | -   | -   | -           | -                                   | 6       |
| -   | 1   | 1   | 1   | 1   | 1   | 1-2119780-1 | DEPRESSOR, SHEAR                    | 5       |
| -   | 1   | 1   | 1   | 1   | 1   | 4-238011-1  | BLOCK, CRIMPER SPACER               | 4       |
| -   | 1   | 1   | 1   | 1   | 1   | 1633989-8   | CRIMPER, INSULATION, SPECIAL        | 3       |
| -   | 1   | 1   | 1   | 1   | 1   | 1633169-2   | CRIMPER, WIRE, SPECIAL              | 1       |
| -77 | -7  | -6  | -5  | -2  | -1  | PART NO     | DESCRIPTION                         | ITEM NO |

| DIMENSIONS: |         | TOLERANCES UNLESS OTHERWISE SPECIFIED: |         | DATE    |         | NAME    |         |
|-------------|---------|--|---------|---------|---------|---------|---------|
| mm          | 0 PLC ± | 1 PLC ±                                | 2 PLC ± | 3 PLC ± | 4 PLC ± | 5 PLC ± | 6 PLC ± |
| ANGLES      | FINISH  |  |         | WEIGHT  |         | SCALE   |         |
| MATERIAL    | FINISH  |  |         | WEIGHT  |         | SCALE   |         |

Customer Accessible Production Drawing SCALE 1:2 SHEET 1 OF 4 REV H

| LOC |    | DIST |     | REVISIONS   |      |     |      |  |
|-----|----|------|-----|-------------|------|-----|------|--|
| A   | 66 | P    | LYN | DESCRIPTION | DATE | OWN | APVD |  |
|     |    | -    |     | SEE SHEET 1 |      |     |      |  |

### FEED TYPE MECHANICAL

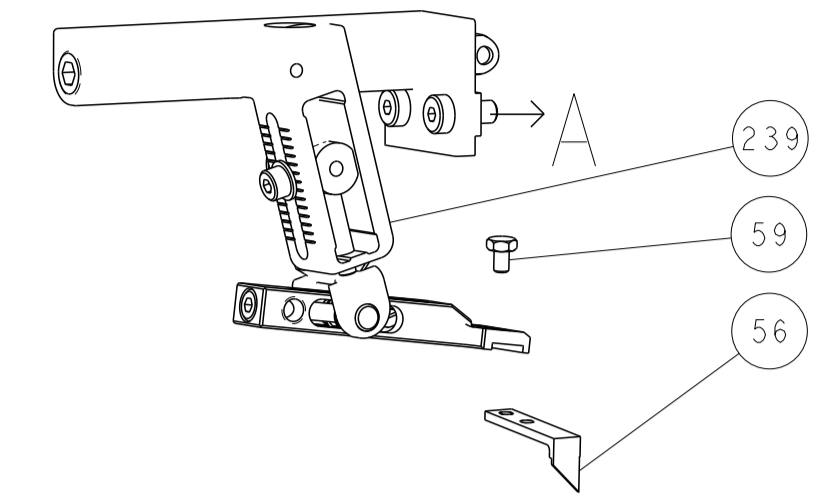

### PNEUMATIC

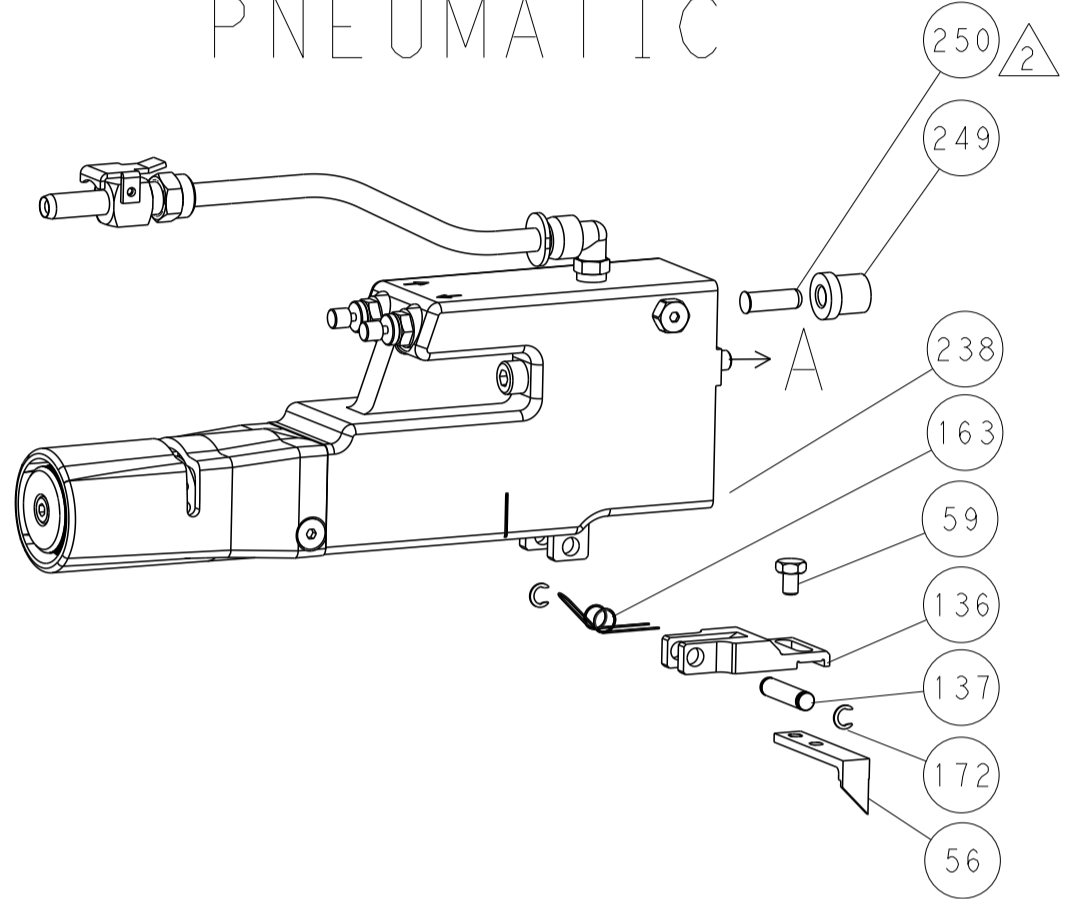

### SERVO LATCH PLATE



### CAM POSITIONS

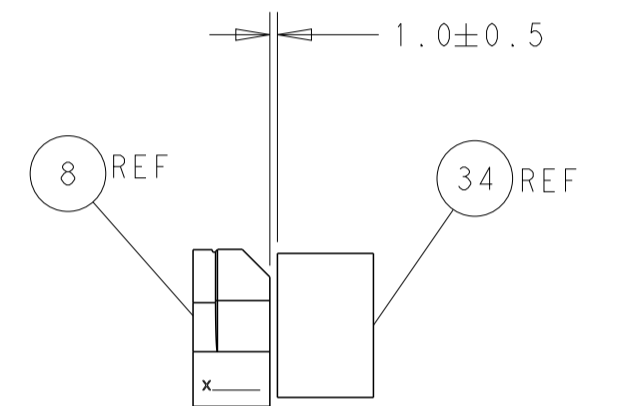
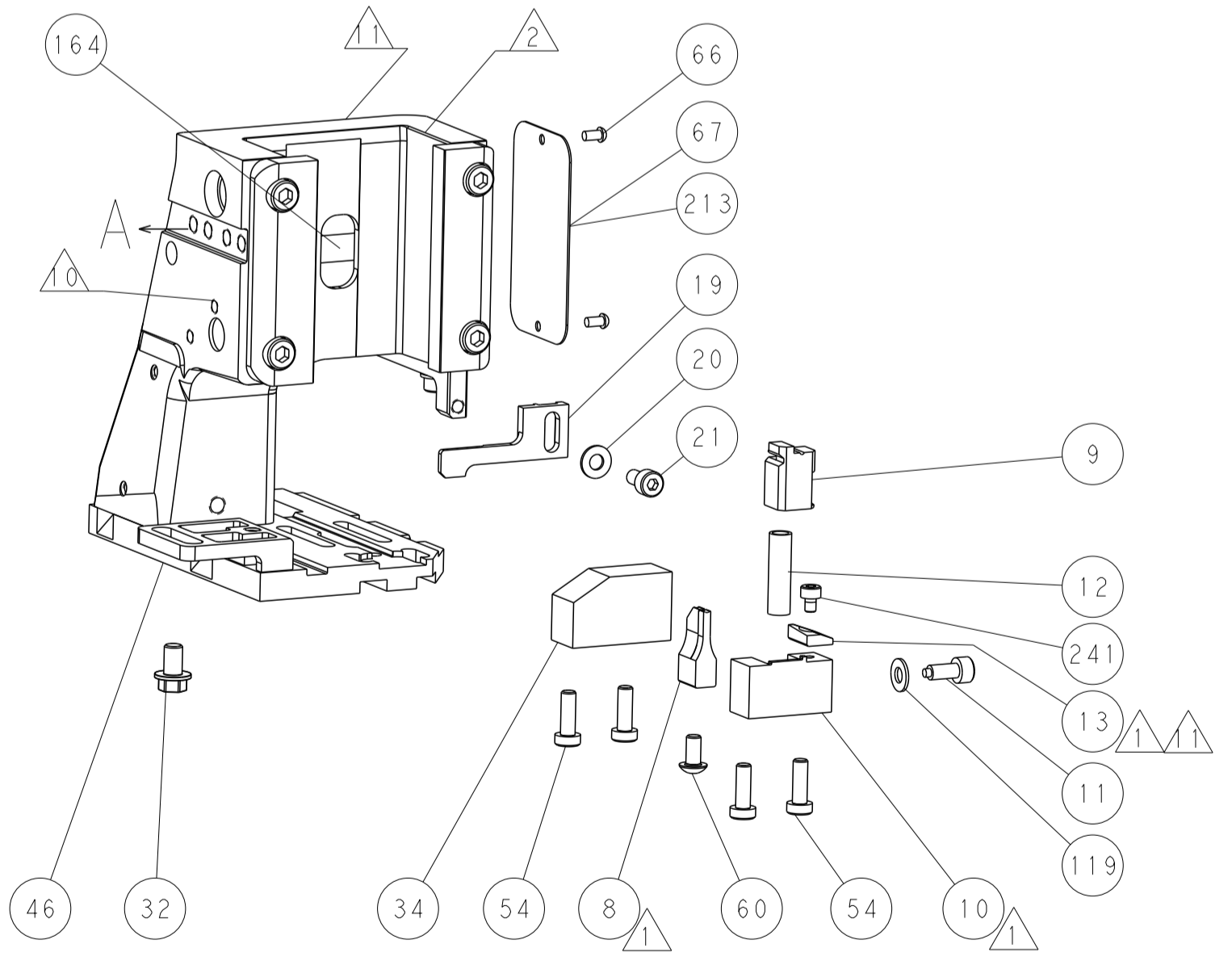
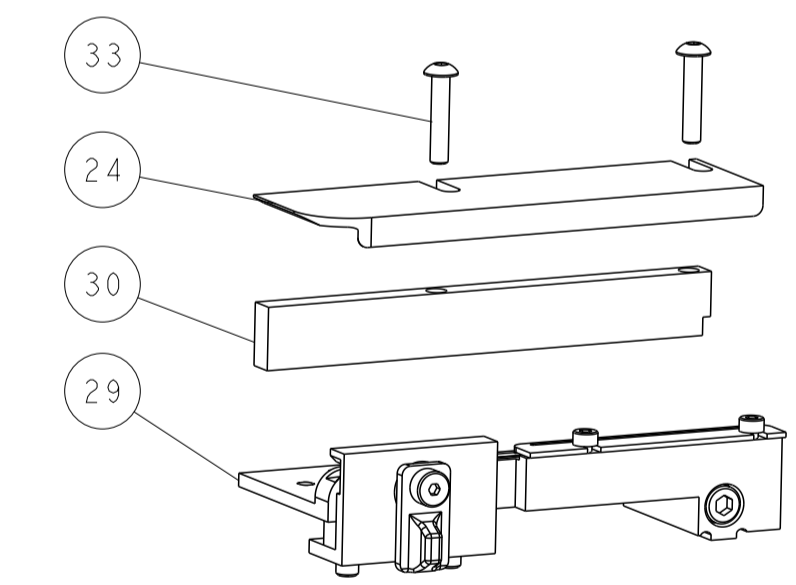
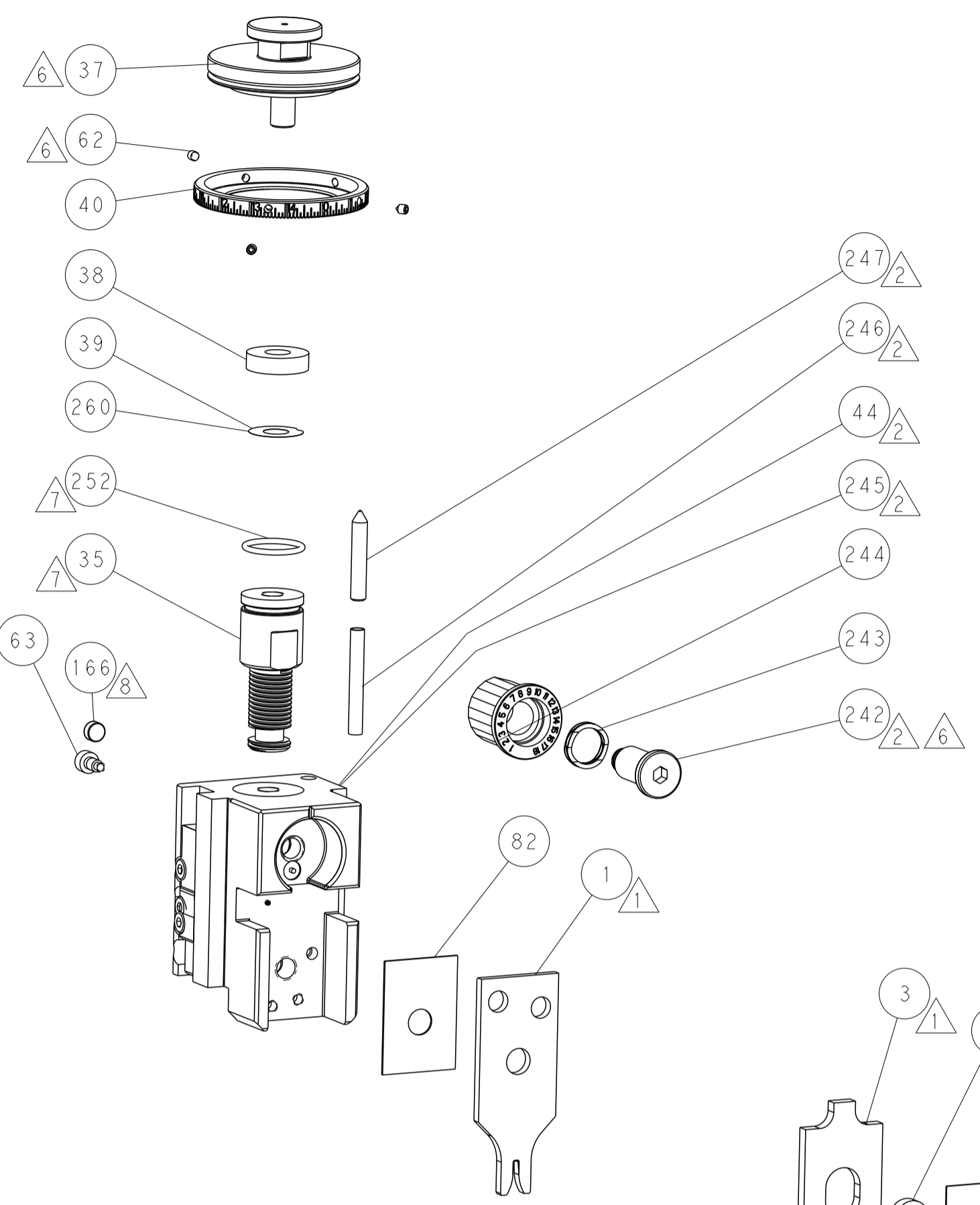

TERMINAL SUPPORT LOCATION

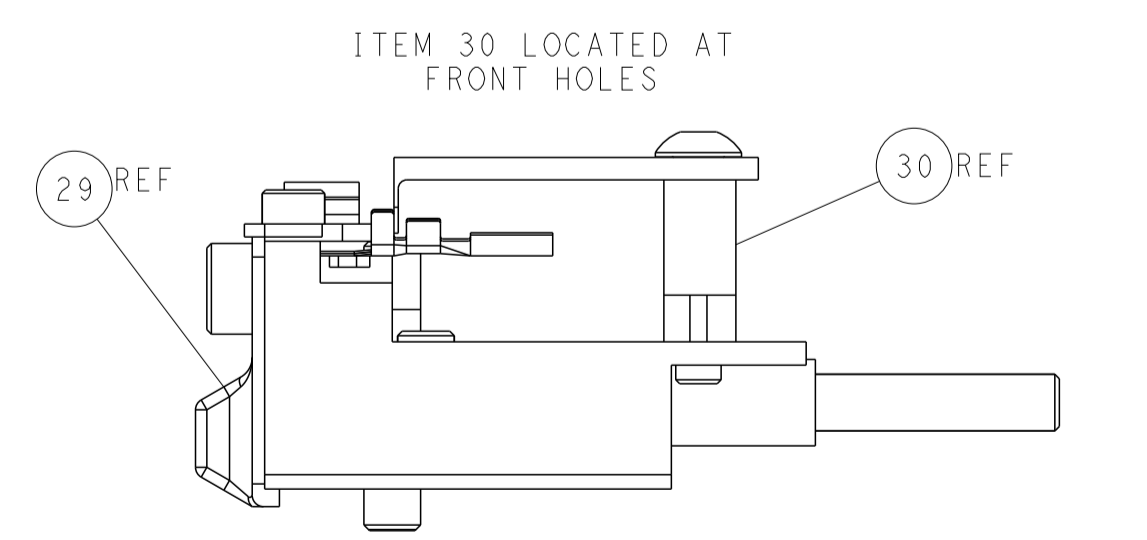

FEED TRACK POSITION GUIDE BY INSULATION BARREL

**ATLANTIC VERSION**  
 Shown on sheets 1 of 4 & 2 of 4  
 (Pacific version shown on sheets 3 of 4 & 4 of 4)

|  |  |  |   |
|--|--|--|---|
| <small>THIS DRAWING IS UNPUBLISHED. RELEASED FOR PUBLICATION BY TYCO ELECTRONICS CORPORATION. ALL RIGHTS RESERVED.</small>       |  | DWN L. ZHANG 26 JUL 2012<br>CHK L. ZHANG 26 JUL 2012<br>S. XI 26 JUL 2012<br>APVD S. XI 26 JUL 2012                                  | TE Connectivity<br>Harrisburg, PA 17105-3608  |
| DIMENSIONS: mm<br>TOLERANCES UNLESS OTHERWISE SPECIFIED:<br>0 PLC ±<br>1 PLC ±<br>2 PLC ±<br>3 PLC ±<br>4 PLC ±<br>ANGLES FINISH |  | NAME Ocean Side Feed Applicator<br>SIZE CAGE CODE DRAWING NO. A1 00779 C=2151353<br>WEIGHT<br>Customer Accessible Production Drawing | RESTRICTED TO<br>SCALE 1:2 SHEET 2 OF 4 REV H |

| PACIFIC VERSION TERMINATOR INTERFACE ADAPTER | PART NUMBER | REVISION | DESCRIPTION              | FEED TYPE         | APPLICATOR STYLE CONVERSION CHART |                       |           |             |           |           |                        |
|--|-------------|----------|--------------------------|-------------------|-----------------------------------|-----------------------|-----------|-------------|-----------|-----------|------------------------|
|  |             |          |                          |                   | CONVERT TO                        | PART NUMBERS REQUIRED |           |             |           |           |                        |
|  | 2-2151353-1 | H        | FINE CRIMP HEIGHT ADJUST | MECHANICAL        | PNEUMATIC FEED                    | 2119950-1             | 1338685-1 | 5-18022-5   | 2119641-2 | 2119799-1 | 2063440-1              |
|  |             |          |                          |                   | SERVO LATCH PLATE                 | 2119951-1             | 2119944-1 | 8-2151353-5 | 1901094-3 | 1976043-1 | 2168400-6 (QUANTITY 2) |
|  |             |          |                          |                   | SMART APPLICATOR                  | 2161326-1             | -         | 8-2151353-4 | -         | -         | -                      |
|  | 2-2151353-2 | H        | FINE CRIMP HEIGHT ADJUST | PNEUMATIC         | MECHANICAL FEED                   | 2119949-1             | 1338685-1 | 5-18022-5   | 2119653-2 | -         | -                      |
|  |             |          |                          |                   | SERVO LATCH PLATE                 | 2119951-1             | 2119944-1 | 8-2151353-5 | 1901094-3 | 1976043-1 | 2168400-6 (QUANTITY 2) |
|  |             |          |                          |                   | SMART APPLICATOR                  | 2161326-1             | -         | 8-2151353-4 | -         | -         | -                      |
|  | 2-2151353-5 | H        | FINE CRIMP HEIGHT ADJUST | SERVO LATCH PLATE | MECHANICAL FEED                   | 2119949-1             | 1338685-1 | 5-18022-5   | 2119653-2 | -         | -                      |
|  |             |          |                          |                   | PNEUMATIC FEED                    | 2119950-1             | 1338685-1 | 5-18022-5   | 2119641-2 | 2119799-1 | 2063440-1              |
|  | 2-2151353-7 | H        | FINE CRIMP HEIGHT ADJUST | NONE              | -                                 | -                     | -         | -           | -         | -         | -                      |
|  | 7-2151353-7 | A        | CRIMP TOOLING KIT        | -                 | -                                 | -                     | -         | -           | -         | -         | -                      |

| APPLICATOR DATA                      |                |      |
|--------------------------------------|----------------|------|
| CRIMP                                | SIZE           | TYPE |
| WIRE                                 | 1.78 mm [.070] | F    |
| INSUL                                | 2.29 mm [.090] | BX   |
| APPLICATOR INSTRUCTIONS<br>408-10389 |                |      |

| TERMINAL DATA: TE TERMINAL         |             | TE CRIMP SPECIFICATION       |             |
|------------------------------------|-------------|------------------------------|-------------|
| TERMINAL NAME: MCON 1.2 LL         |             |                              |             |
| WIRE STRIP LENGTH                  |             | INSULATION DIAMETER RANGE    |             |
| 3.30-3.90 mm [1.30-.154 IN]        |             | Ø1.90-2.40 mm [.075-.094 IN] |             |
| TERMINAL APPLICATION SPECIFICATION | 114-18464   | -                            | -           |
| TERMINALS APPLIED                  |             |                              |             |
| TE TERMINAL                        | TE TERMINAL | TE TERMINAL                  | TE TERMINAL |
| 1452659-1                          | 1452659-2   | 1452659-3                    |             |
| 7-1452659-1                        | 7-1452659-2 | 7-1452659-3                  |             |

| WIRE SIZE | CRIMP HEIGHT mm [INCH]      | CRIMP HEIGHT REFERENCE SETTING |
|-----------|-----------------------------|--------------------------------|
| 1.50mm2   | 1.31+/-0.05 [0.052+/-0.002] | 8.0                            |
| 16 AWG    | 1.26+/-0.05 [0.050+/-0.002] | 8.5                            |
| 1.00mm2   | 1.10+/-0.05 [0.043+/-0.002] | 10.0                           |
| 18 AWG    | 1.05+/-0.05 [0.041+/-0.002] | 10.6                           |

- RECOMMENDED SPARE PARTS
- GREASE BEARING SURFACES LIGHTLY
- 3. LUBRICATE DAILY PER THE APPLICATOR INSTRUCTION SHEET SUPPLIED WITH THE APPLICATOR.
- APPLICATOR SPECIFIC DATA TO BE ENTERED INTO BLANK MEMORY CHIP AT ASSEMBLY. SEE BELOW FOR PART NUMBER:  
 MECHANICAL FEED WITH "SMART APPLICATOR" CONVERSION: 8-2151353-4  
 PNEUMATIC FEED WITH "SMART APPLICATOR" CONVERSION: 8-2151353-4  
 SERVO FEED WITH "FINE CRIMP HEIGHT ADJUST": 8-2151353-5
- 5. ADJUSTMENT OF THE STRIPPER MAY BE REQUIRED WHEN MOVING THE APPLICATOR BETWEEN BENCH AND LEADMAKER APPLICATIONS.
- APPLY PART NUMBER 1-23419-5 LOCTITE TO THREADS OF ITEM 62.  
 APPLY PART NUMBER 2-23419-6 LOCTITE TO THREADS OF ITEM 242.
- GREASE THREADS, GROOVE AND O-RING ON ITEMS 139 & 152.
- MAGNET MUST BE ORIENTED CORRECTLY IN ORDER TO PROPERLY ACTUATE THE COUNTER.
- CRIMP HEIGHT REFERENCE SETTING WAS THE SETTING USED WHEN THE APPLICATOR WAS QUALIFIED AT THE FACTORY. ADJUSTMENT MAY BE NECESSARY WHEN RUNNING APPLICATOR IN THE FIELD.
- SPARE FEED CAM STORAGE LOCATION REFER TO INSTRUCTION SHEET FOR ADDITIONAL INFORMATION.
- TO CONVERT THE APPLICATOR TO A NON-CARRIER CUTTING STYLE, REMOVE ITEM 13 AND ATTACH TO THE LOCATION ON BACK SIDE OF THE HOUSING. REFER TO INSTRUCTION SHEET FOR ADDITIONAL INFORMATION.
- TERMINAL LUBRICANT IS RECOMMENDED.

**\*WARNING**  
 ON INSTALLATION, SET WIRE DISC, ITEM 40 TO LARGEST WIRE SIZE SETTING. USE OF SETTINGS BELOW MINIMUM REQUIRED CRIMP HEIGHT SETTING WILL CAUSE DAMAGE TO CRIMP TOOLING.

|     |     |     |     |     |           |                                     |         |
|-----|-----|-----|-----|-----|-----------|-------------------------------------|---------|
| -   | 1   | 1   | 1   | 1   | 2119782-1 | FINE ADJUST HEAD ASM, PACIFIC STYLE | 251     |
| -77 | -27 | -25 | -22 | -21 | PART NO   | DESCRIPTION                         | ITEM NO |

**PACIFIC VERSION**  
 Shown on sheets 3 of 4 & 4 of 4  
 (Atlantic version shown on sheets 1 of 4 & 2 of 4)

| SET UP GAUGE | LOC | DIST | REVISIONS   |      |    |      |
|--------------|-----|------|-------------|------|----|------|
| 2119599-1    | A   | 66   | REV         | DATE | BY | APPD |
| -            | -   | -    | SEE SHEET 1 | -    | -  | -    |

|   |     |     |     |     |             |                                     |     |
|---|-----|-----|-----|-----|-------------|-------------------------------------|-----|
| - | -   | -   | 1   | -   | 2119640-1   | PUSH ROD, AIR FEED                  | 250 |
| - | -   | -   | 1   | -   | 1803259-1   | BUSHING, FLANGED                    | 249 |
| - | 1   | 1   | 1   | 1   | 1-22279-3   | SPRING, COMPRESSION                 | 246 |
| - | 1   | 1   | 1   | 1   | 2119082-4   | CAM, SNAIL, INSULATION ADJUSTMENT   | 244 |
| - | 1   | 1   | 1   | 1   | 2079764-1   | WASHER, WAVE SPRING, CREST-TO-CREST | 243 |
| - | 1   | 1   | 1   | 1   | 2119083-1   | RETAINER, INSULATION DIAL           | 242 |
| - | 1   | 1   | 1   | 1   | 7-18023-7   | SCR, SKT HD CAP M3 X 4.0            | 241 |
| - | -   | 2   | -   | -   | 2168400-6   | SHCS, LOW HEAD, RoHS, M5 X 16       | 240 |
| - | -   | -   | -   | 1   | 2119580-1   | MECHANICAL FEED ASSEMBLY            | 239 |
| - | -   | -   | -   | 1   | 2063440-1   | AIR FEED MODULE                     | 238 |
| - | -   | 1   | -   | -   | 2119740-2   | TAG, IDENTIFICATION                 | 213 |
| - | -   | 1   | -   | -   | 1901094-3   | SPACER, FEEDER                      | 198 |
| - | -   | -   | 2   | -   | 21045-3     | RING, RETAIN, EXTERN, 3/16 CRESCENT | 172 |
| - | 1   | 1   | 1   | 1   | 994969-1    | MAGNET, RARE EARTH HIGH ENERGY      | 166 |
| - | REF | REF | REF | REF | 994970-2    | COUNTER, MAGNETIC                   | 164 |
| - | -   | -   | 1   | -   | 240638-1    | SPRING, FEED FINGER                 | 163 |
| - | 1   | 1   | 1   | 1   | 8-21084-1   | O-RING, .801 ID, .070 DIA. MAT.     | 152 |
| - | -   | -   | 1   | -   | 2119641-2   | FEED CAM, AIR FEED                  | 151 |
| - | 1   | 1   | 1   | 1   | 2119798-2   | DETENT PIN                          | 145 |
| - | 1   | 1   | 1   | 1   | 2079383-8   | SCR, BHSC, RoHS (M4 X 16)           | 144 |
| - | 4   | 4   | 4   | 4   | 2168400-5   | SHCS, LOW HEAD, RoHS, M4 X 20       | 143 |
| - | -   | -   | -   | 1   | 2119653-2   | FEED CAM, POST FEED                 | 142 |
| - | 1   | 1   | 1   | 1   | 1-2119656-0 | APPLICATOR BASIC ASSEMBLY, SF       | 141 |
| - | 1   | 1   | 1   | 1   | 2119650-1   | RAM, ASIAN STYLE, SIDE FEED         | 140 |
| - | 1   | 1   | 1   | 1   | 2119092-2   | BOLT, ADJUSTMENT                    | 139 |
| - | -   | -   | 1   | -   | 3-23627-7   | PIN, RETAIN, GRVD, 3/16 X .854      | 137 |
| - | -   | -   | 1   | -   | 2119799-1   | HOLDER, FEED FINGER, AF             | 136 |
| - | -   | REF | -   | -   | -           | SEE NOTE 4                          | 135 |
| - | -   | 1   | -   | -   | 1633743-1   | SERVO FEED LATCH ASM                | 133 |
| - | 1   | 1   | 1   | 1   | 1-18028-2   | WASHER, FLAT, REG M4                | 119 |
| - | -   | REF | -   | -   | 2119944-1   | FEED FINGER ASSEMBLY, SF            | 117 |
| - | 1   | 1   | 1   | 1   | 2119955-1   | ASSY, LUBRICATOR, SIDE FEED         | 113 |
| - | 1   | 1   | 1   | 1   | 455888-5    | SPACER, CRIMPER                     | 82  |
| - | 1   | 1   | 1   | 1   | 22278-8     | SPRING, COMPRESSION                 | 77  |
| - | 1   | 1   | 1   | 1   | 854769-4    | HOLDER, INS                         | 74  |
| - | 1   | 1   | 1   | 1   | 2119956-1   | DOCUMENTATION PACKAGE               | 71  |
| - | 1   | -   | 1   | 1   | 2119740-1   | TAG, IDENTIFICATION                 | 67  |
| - | 2   | 2   | 2   | 2   | 2168078-1   | SCREW, DRIVE, RH, RoHS, 2 x .188    | 66  |
| - | 1   | 1   | 1   | 1   | 2119793-1   | LIMITER, ADJUSTMENT BOLT            | 63  |
| - | 3   | 3   | 3   | 3   | 992763-5    | SCR, SET, SOC, CONE POINT, M3 x 4.0 | 62  |
| - | -   | -   | 1   | 1   | 5-18022-5   | SCR, HEX HD CAP, M4 X 6.0           | 59  |
| - | 1   | 1   | 1   | 1   | 21028-2     | PIN, SLOTTED SPRING .062 X .250     | 58  |
| - | -   | -   | 1   | 1   | 1338685-1   | PAWL, FEED                          | 56  |
| - | 2   | 2   | 2   | 2   | 1-2168083-0 | SCR, SKT HD CAP, RoHS, M4 X 10      | 53  |
| - | -   | -   | 1   | 2   | 18023-9     | SCR, SKT HD CAP M4 X 6.0            | 49  |
| - | -   | -   | -   | 1   | 2119652-1   | FEED CAM, PRE FEED                  | 48  |
| - | 1   | 1   | 1   | 1   | 2079383-7   | SCR, BHSC, RoHS (M8 X 25)           | 41  |
| - | 1   | 1   | 1   | 1   | 2119645-1   | DISC, NUMBERED FA WIRE ADJUSTMENT   | 40  |
| - | 1   | 1   | 1   | 1   | 2119957-1   | APPLICATOR SHIM PACK                | 39  |
| - | 1   | 1   | 1   | 1   | 1-2119644-2 | RAM WASHER, PRECISION               | 38  |
| - | 1   | 1   | 1   | 1   | 1752356-6   | SUPPORT, TERMINAL                   | 34  |
| - | 2   | 2   | 2   | 2   | 2079383-5   | SCR, BHSC, RoHS (M4 X 20)           | 33  |
| - | 1   | 1   | 1   | 1   | 2161328-1   | HEX HEAD, FLANGED, M5 x 8mm LONG    | 32  |
| - | 1   | 1   | 1   | 1   | 1320908-3   | SPACER, STRIP GUIDE                 | 30  |
| - | 1   | 1   | 1   | 1   | 2119959-2   | ASSEMBLY, STRIP GUIDE               | 29  |
| - | 1   | 1   | 1   | 1   | 455888-4    | SPACER, CRIMPER                     | 28  |
| - | 1   | 1   | 1   | 1   | 1320928-2   | STRIP GUIDE                         | 24  |
| - | 1   | 1   | 1   | 1   | 2168083-2   | SCR, SKT HD CAP, RoHS, M4 X 8.0     | 21  |
| - | 3   | 3   | 3   | 3   | 1-18028-2   | WASHER, FLAT, REG M4                | 20  |
| - | 1   | 1   | 1   | 1   | 2119533-1   | STRIPPER, SIDE FEED                 | 19  |
| - | 1   | 1   | 1   | 1   | 1333264-1   | HOLD DOWN                           | 18  |
| - | 1   | 1   | 1   | 1   | 2119806-1   | INSERT, SHEAR                       | 13  |
| - | 1   | 1   | 1   | 1   | 3-22280-3   | SPRING, COMPRESSION                 | 12  |
| - | 1   | 1   | 1   | 1   | 1-356885-4  | STOP, SHEAR                         | 11  |
| - | 1   | 1   | 1   | 1   | 2119805-1   | SHEAR HOLDER, FRONT                 | 10  |
| - | 1   | 1   | 1   | 1   | 1633861-1   | SHEAR, FLOATING                     | 9   |
| - | 1   | 1   | 1   | 1   | 4-1333203-2 | ANVIL, COMBINATION                  | 8   |
| - | -   | -   | -   | -   | -           | -                                   | 7   |
| - | -   | -   | -   | -   | -           | -                                   | 6   |
| - | 1   | 1   | 1   | 1   | 1-2119780-1 | DEPRESSOR, SHEAR                    | 5   |
| - | 1   | 1   | 1   | 1   | 4-238011-1  | BLOCK, CRIMPER SPACER               | 4   |
| - | 1   | 1   | 1   | 1   | 1633989-8   | CRIMPER, INSULATION, SPECIAL        | 3   |
| - | 1   | 1   | 1   | 1   | 1633169-2   | CRIMPER, WIRE, SPECIAL              | 1   |

| DIMENSIONS:                            |         | TOLERANCES UNLESS OTHERWISE SPECIFIED: |           | DATE         |     |
|--|---------|--|-----------|--------------|-----|
| mm                                     | 0 PLC ± | 1 PLC ±                                | 2 PLC ±   | 26 JUL 2012  | CHK |
|  | 3 PLC ± | 4 PLC ±                                | ANGLES ±  | 26 JUL 2012  | CHK |
| MATERIAL                               | FINISH  | WEIGHT                                 | SCALE     | SHEET 3 OF 4 |     |
| Customer Accessible Production Drawing |         |  | SCALE 1:2 | REV H        |     |

| LOC |    | DIST |     | REVISIONS   |      |     |      |
|-----|----|------|-----|-------------|------|-----|------|
| A   | 66 | P    | LTM | DESCRIPTION | DATE | OWN | APVD |
|     |    | -    |     | SEE SHEET 1 |      |     |      |

# FEED TYPE MECHANICAL

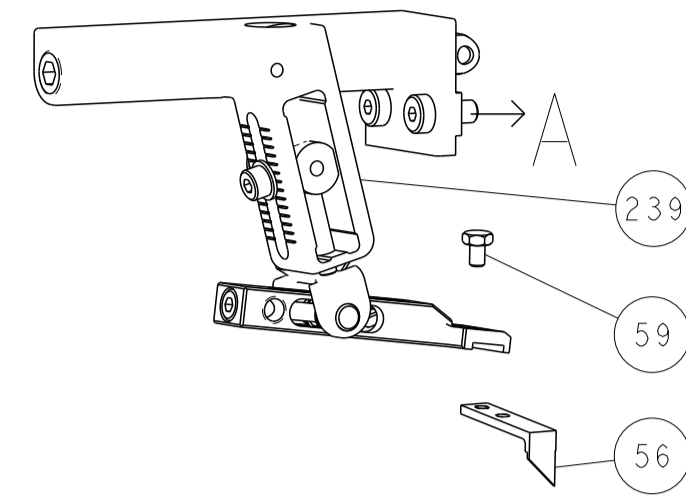

# PNEUMATIC

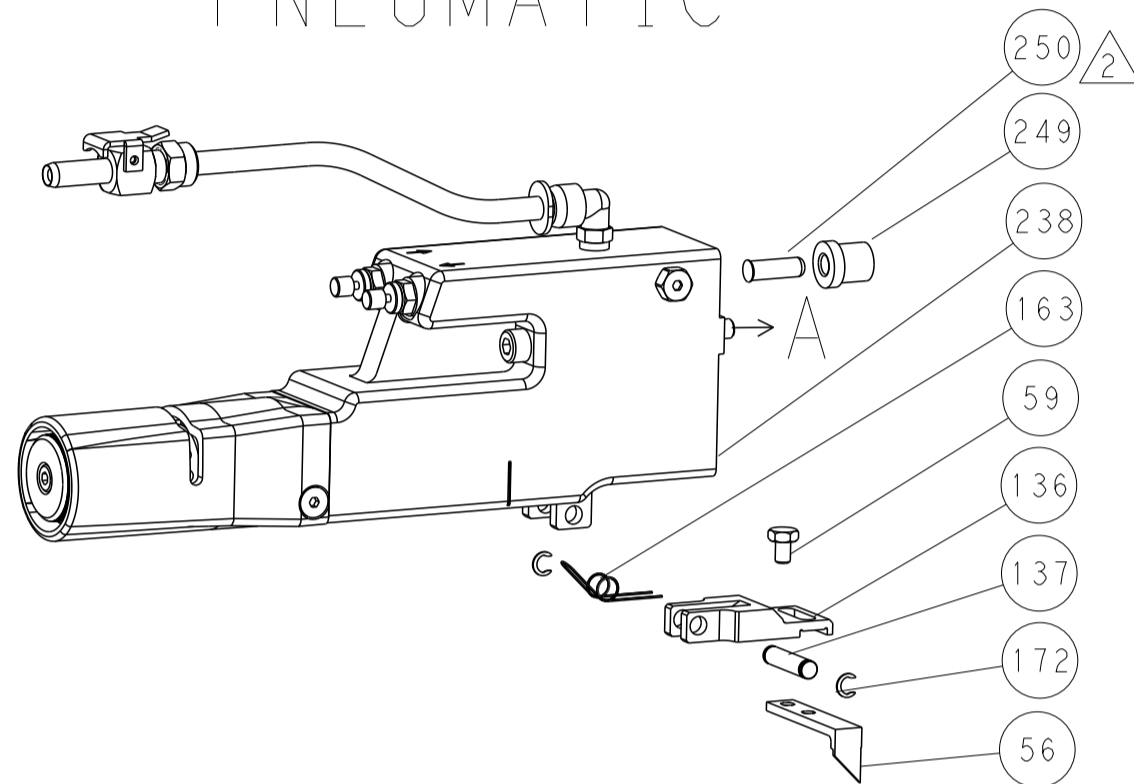

# SERVO LATCH PLATE

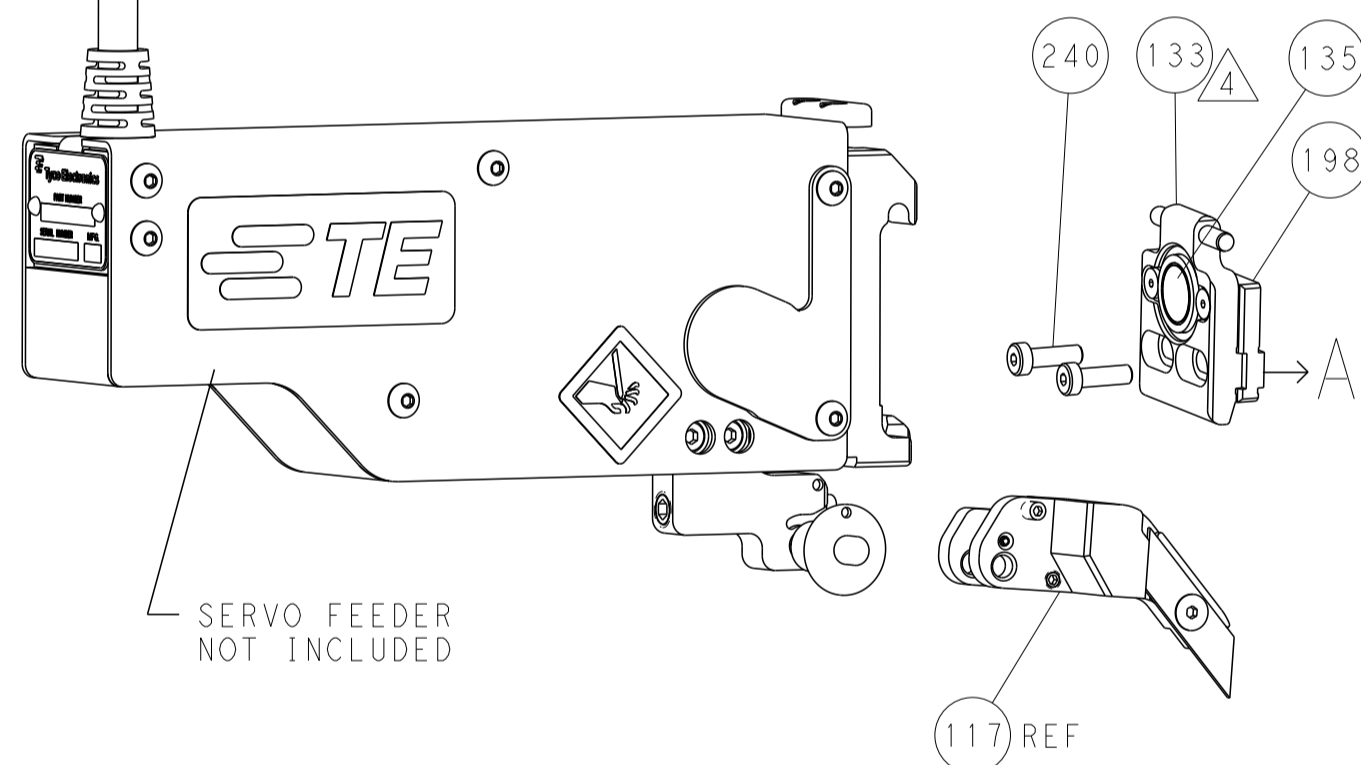

# CAM POSITIONS

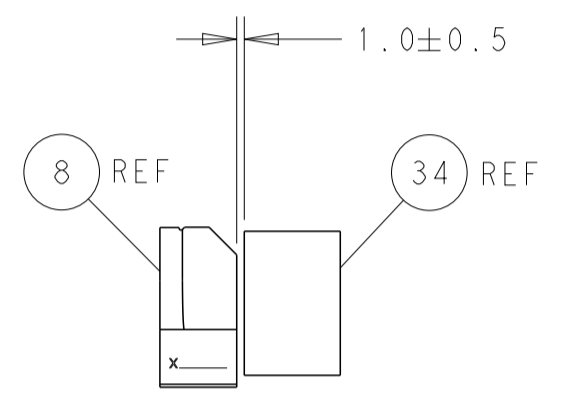
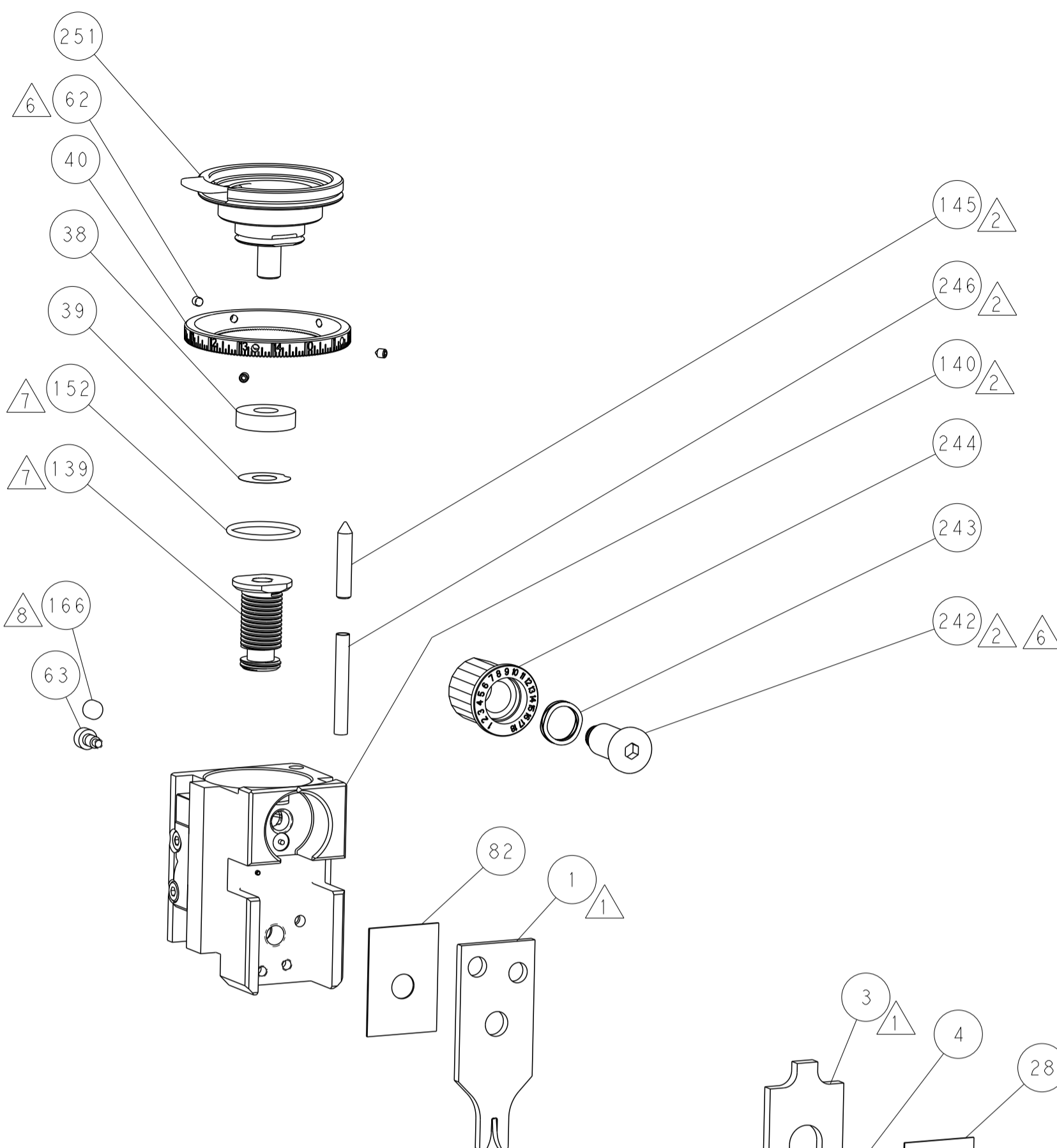
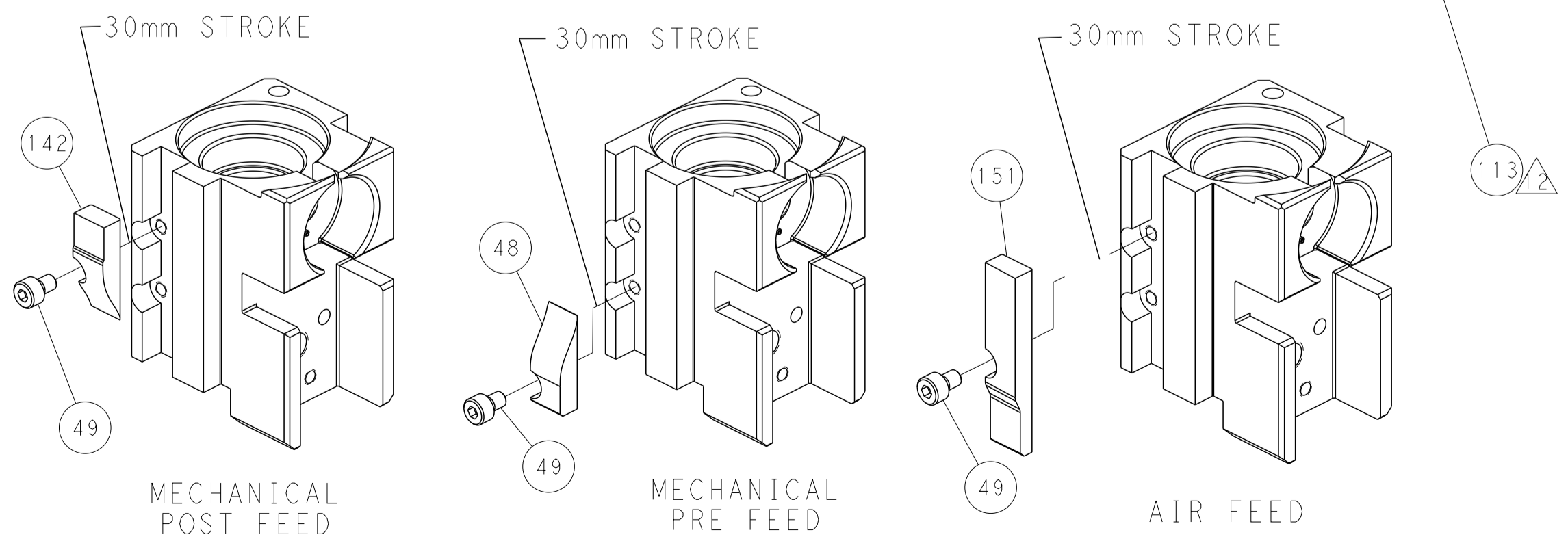

TERMINAL SUPPORT LOCATION

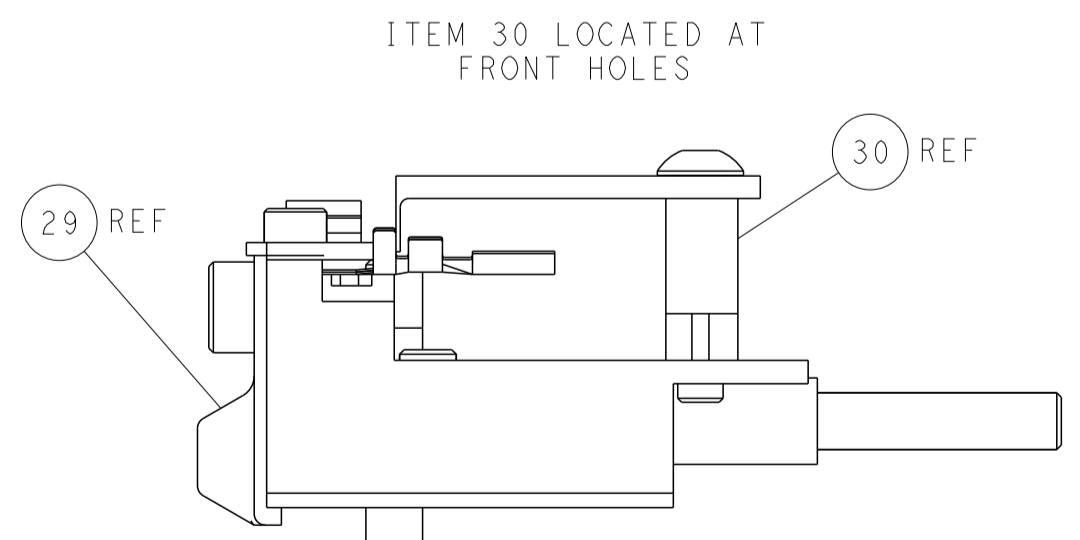
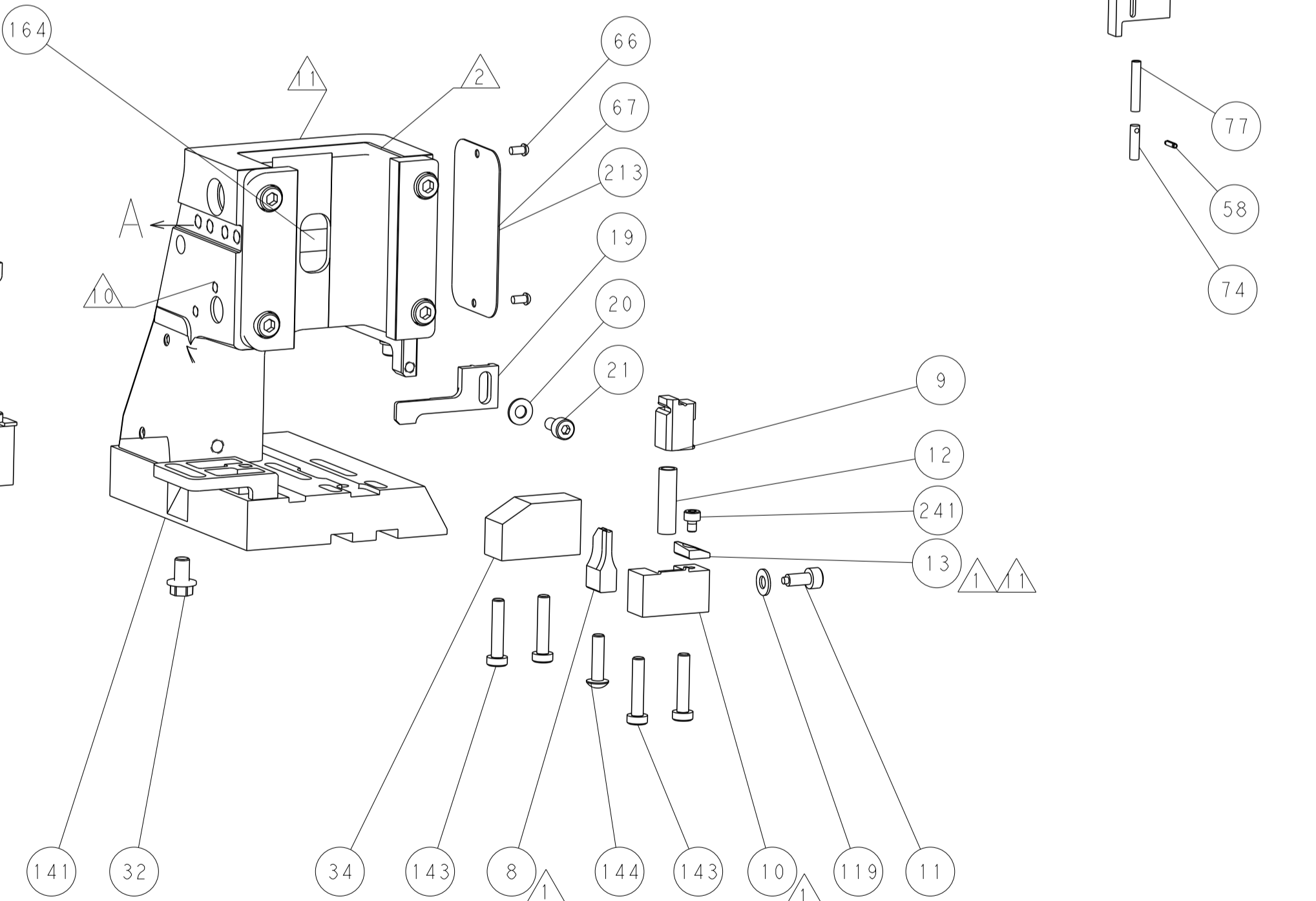

FEED TRACK POSITION  
GUIDE BY INSULATION BARREL

**PACIFIC VERSION**  
 Shown on sheets 3 of 4 & 4 of 4  
 (Atlantic version shown on sheets 1 of 4 & 2 of 4)

|             |         |  |         |  |         |                              |                           |
|-------------|---------|--|---------|--|---------|------------------------------|---------------------------|
| DIMENSIONS: |         | TOLERANCES UNLESS OTHERWISE SPECIFIED: |         | DWN L. ZHANG 26 JUL 2012               |         | TE Connectivity              |                           |
| mm          | 0 PLC ± | 1 PLC ±                                | 2 PLC ± | 3 PLC ±                                | 4 PLC ± | 5 PLC ±                      | Harrisburg, PA 17105-3608 |
| MATERIAL:   |         | FINISH:                                |         | CHK L. ZHANG 26 JUL 2012               |         | NAME                         |                           |
|             |         |  |         | S. XI 26 JUL 2012                      |         | Ocean Side Feed              |                           |
|             |         |  |         | APVD                                   |         | Applicator                   |                           |
|             |         |  |         | PRODUCT SPEC                           |         | SIZE CAGE CODE DRAWING NO    |                           |
|             |         |  |         | APPLICATION SPEC                       |         | A1 00779 C=2151353           |                           |
|             |         |  |         | WEIGHT                                 |         | RESTRICTED TO                |                           |
|             |         |  |         | Customer Accessible Production Drawing |         | SCALE 1:2 SHEET 4 OF 4 REV H |                           |