

THIS DRAWING IS UNPUBLISHED. RELEASED FOR PUBLICATION
 © COPYRIGHT BY TYCO ELECTRONICS CORPORATION. ALL RIGHTS RESERVED.

LOC		DIST		REVISIONS			
P	LTR	DESCRIPTION	DATE	DWN	APVD		
AF	50	J	REVIS PER ECR-06-010427	31AUG06	HMR	KR	

- 1 CONTINUOUS STRIP ON REELS WITH TERMINALS LOCATED ON 8.38±0.08 [.330±.003] CENTERS.
- 2 SLOTTED ACCEPTS 0.64-0.81mm DIA [#22-#20] AWG COPPER MAGNET WIRE. TWO WIRES OF THE SAME SIZE MAX PER SLOT.
- 3 AFTER INSERTION INTO PLASTIC HOLDER, TAB PORTION MUST BE BENT OVER 45° TO 90° OR POTTED-IN TO PREVENT PULL-OUT WHEN MATING RECEPTACLE IS DISCONNECTED.
- 4 VARNISH RESIST OVER 0.002032 [.000080] MIN TIN PLATE.

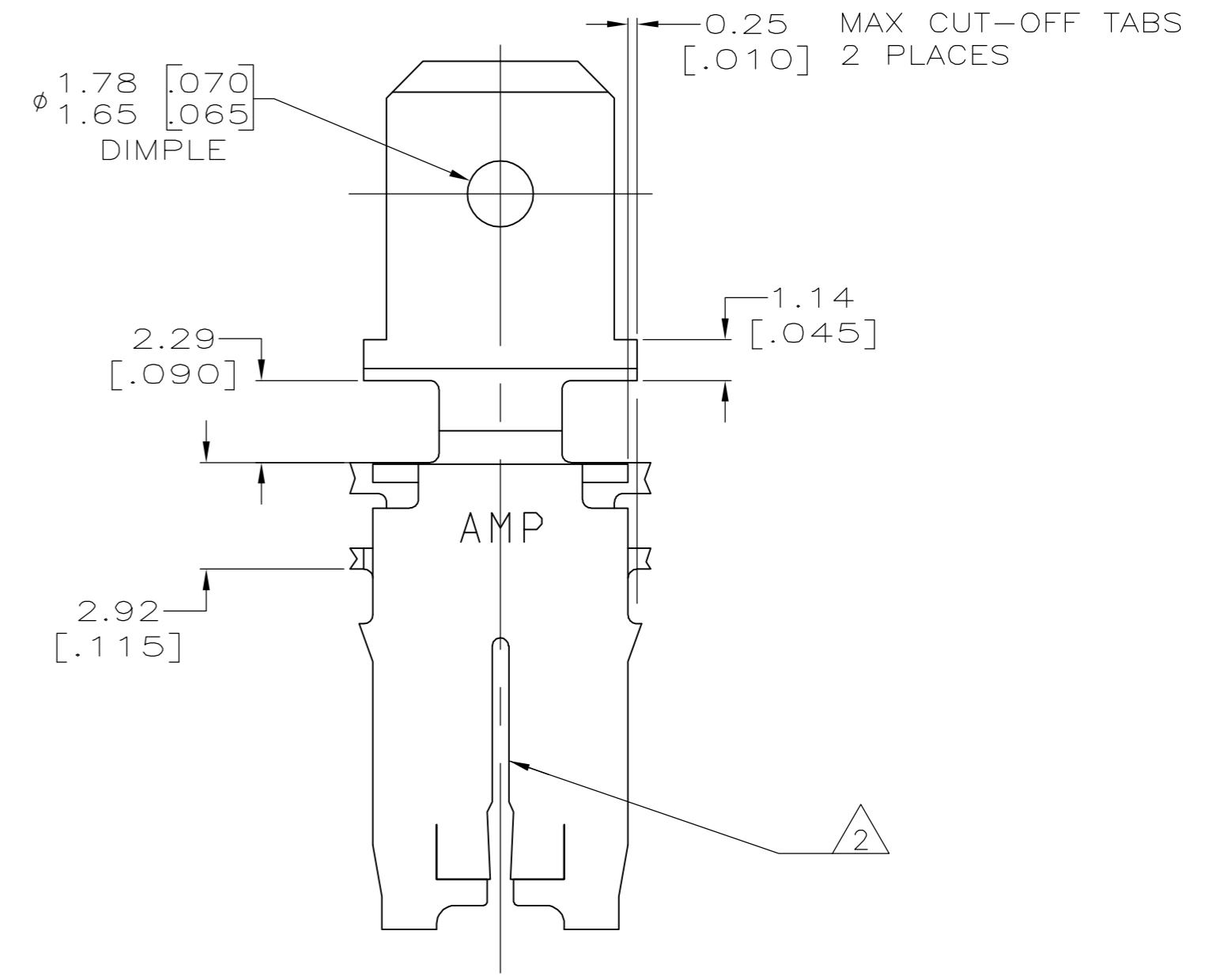
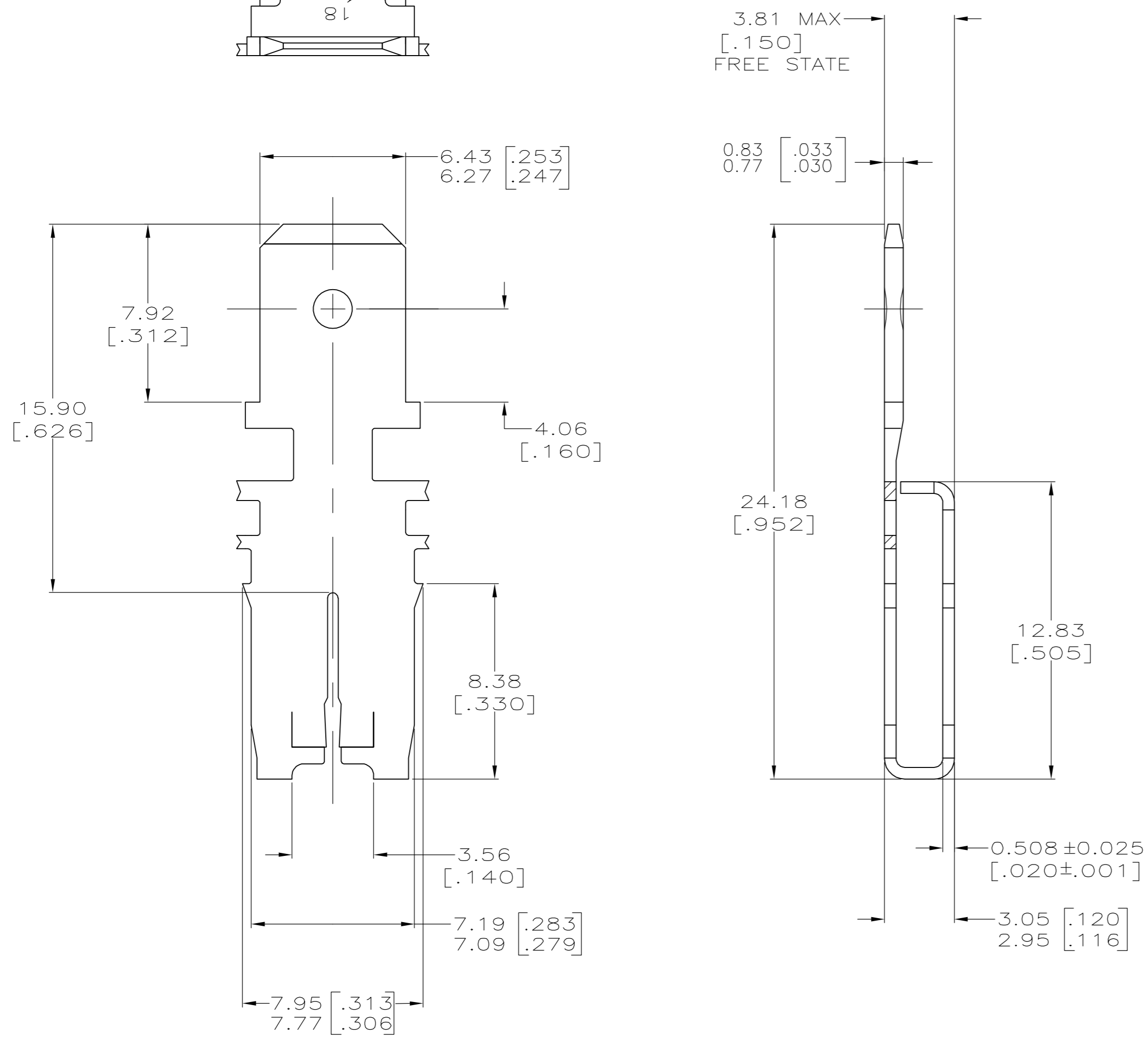

63155-1
PART NUMBER

THIS DRAWING IS A CONTROLLED DOCUMENT.		DWN MICHAEL S. FEHER 07MAY1999	tyco Electronics Tyco Electronics Corporation Harrisburg, PA 17105-3608	
DIMENSIONS: mm [INCHES]		CHK JEFF R. RUTH 07JUN1999	NAME KURT A. RANDOLPH	
TOLERANCES UNLESS OTHERWISE SPECIFIED:		APVD KURT A. RANDOLPH 07JUN1999	PRODUCT SPEC 108-2053	
0 PLC ± -		APPLICATION SPEC 114-2066		
1 PLC ± -		SIZE A2		
2 PLC ± 0.25 [.010]		CAGE CODE 00779		
3 PLC ± -		DRAWING NO C=63155		
4 PLC ± -		RESTRICTED TO -		
ANGLES ± -		WEIGHT -		
FINISH		SCALE 6:1		
4M PRE-MILLED BRASS		SHEET 1 of 1		
4		REV J		
CUSTOMER DRAWING				