

Customer Information Sheet

DRAWING No.: S0981-46R

SHEET 2 OF 2

IF IN DOUBT - ASK

©

NOT TO SCALE

THIRD ANGLE PROJECTION

ALL DIMENSIONS IN mm

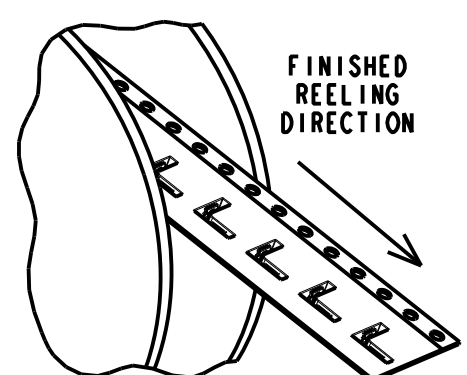
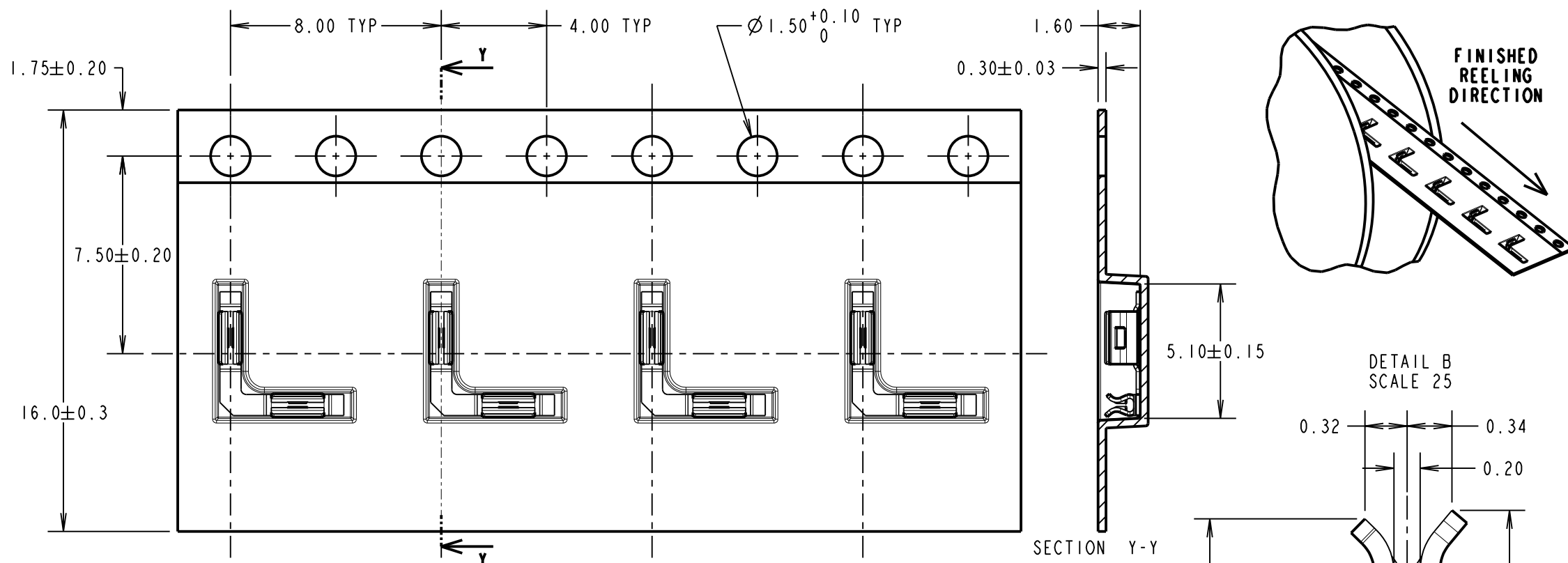

SPECIFICATION:
MATERIAL:
 CONTACT = STAINLESS STEEL
FINISH:
 2.0µm - 3.0µm TIN OVER
 0.4µm - 1.2µm NICKEL.
ELECTRICAL:
 RESISTANCE = 100mΩ MAX
MECHANICAL:
 INSERTION FORCE = 19.6N MAX
 WITHDRAWAL FORCE = 0.98N MIN
 DURABILITY = 10 CYCLES
ENVIRONMENTAL:
 OPERATING TEMPERATURE = -25°C TO +150°C
 STORAGE TEMPERATURE = -40°C TO +85°C
PACKAGING:
 6,000 PARTS IN TAPE AND REEL,
 9 REELS PACKED IN BOX.

NOTES:
 1. MAXIMUM PERMISSIBLE BURR IS 0.03mm MAX.
 2. FOR USE WITH 0.20 - 0.25mm THICK SHIELD CANS.

DETAIL B
SCALE 25

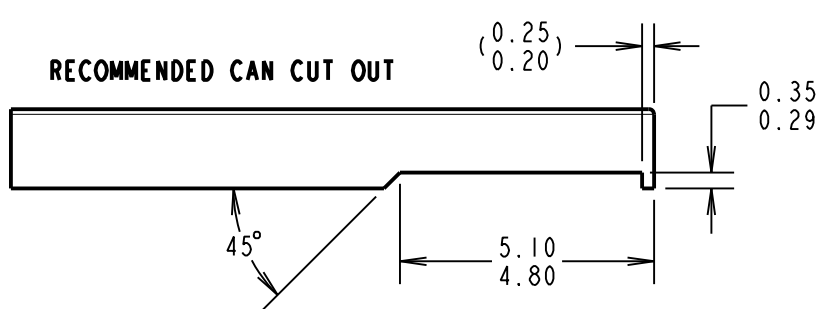
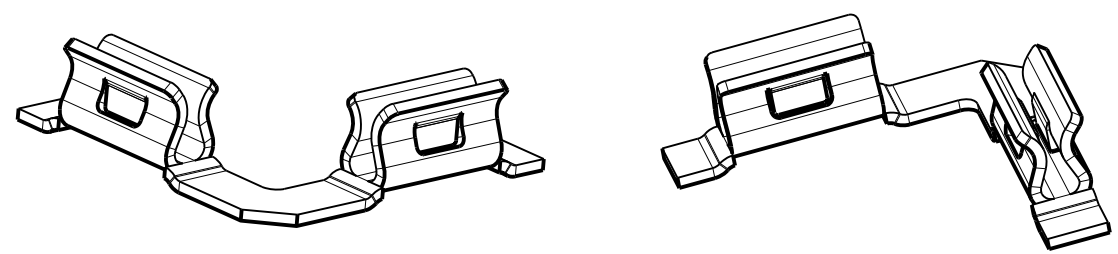
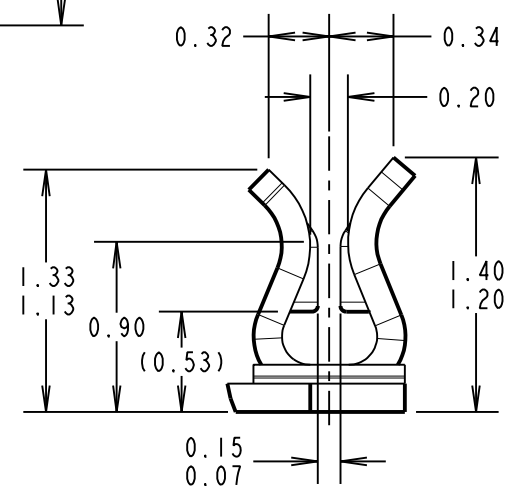

RECOMMENDED PAD LAYOUT (TOLERANCE ±0.10)

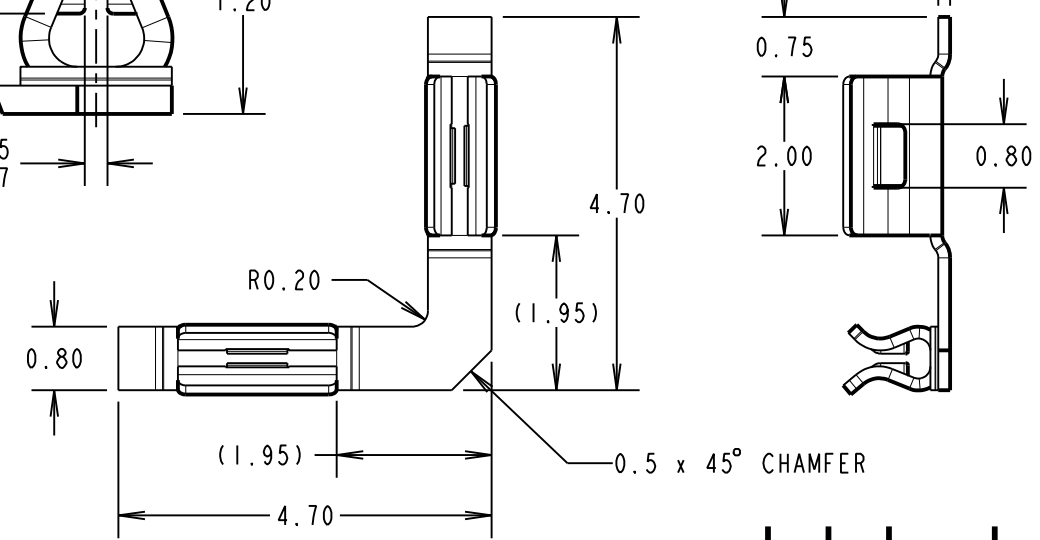
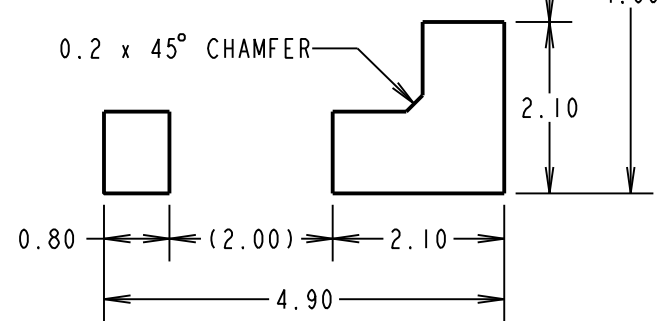

COMPONENT DETAILS (TOLERANCE ±0.05)

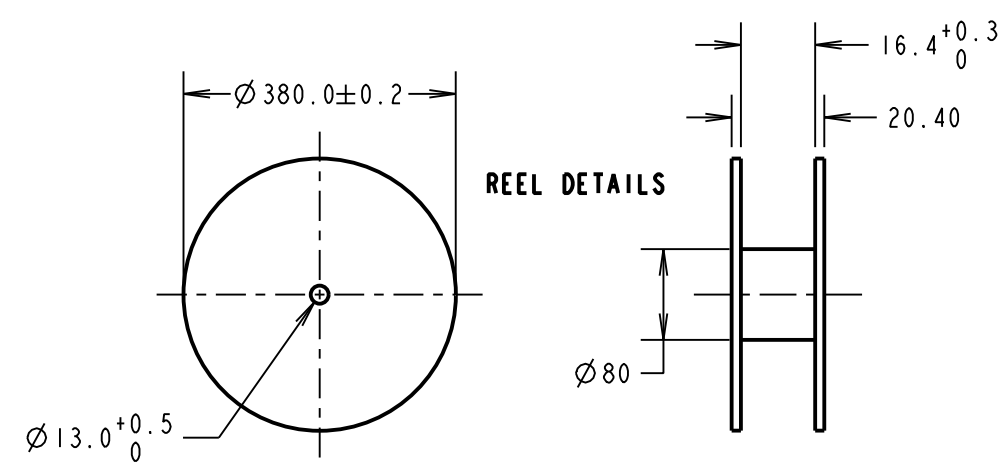
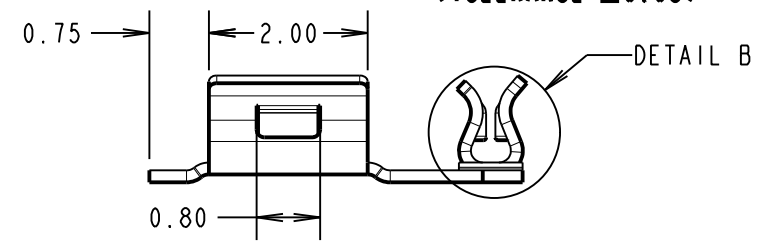

MSP	3	28.09.16	13439
NAME	ISS.	DATE	C/NOTE
APPROVED:		M. PERREN	
CHECKED:		S. BENNETT	
DRAWN:		S. BENNETT	
CUSTOMER REF.:			
ASSEMBLY DRG:			

HARWIN
 www.harwin.com
 technical@harwin.com

THIS DRAWING AND ANY INFORMATION OR DESCRIPTIVE MATTER SET OUT HEREON ARE CONFIDENTIAL AND COPYRIGHT PROPERTY OF THE HARWIN GROUP AND MUST NOT BE DISCLOSED, LOANED, COPIED OR USED FOR MANUFACTURING, TENDERING OR FOR ANY OTHER PURPOSE WITHOUT THEIR WRITTEN PERMISSION.

TOLERANCES
 X. = ±1mm
 X.X = ±0.25mm
 X.XX = ±0.10mm
 X.XXX = ±0.01mm
 ANGLES = ±5°
 UNLESS STATED

MATERIAL:
 SEE ABOVE
FINISH: SEE ABOVE
S/AREA: mm²

TITLE:
 90° SURFACE MOUNT RFI SHIELD CLIP IN TAPE AND REEL
DRAWING NUMBER:
S0981-46R
 SHT 2 OF 2