

13 12 11 10 9 8 7 6 5 4 3 2 1

J  
I  
H  
G  
F  
E  
D  
C  
B  
A

J  
I  
H  
G  
F  
E  
D  
C  
B  
A

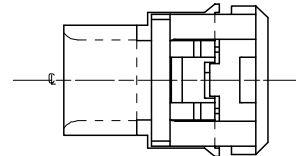
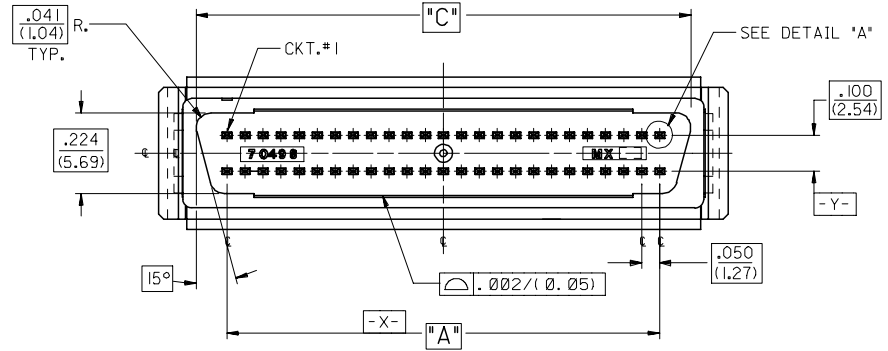
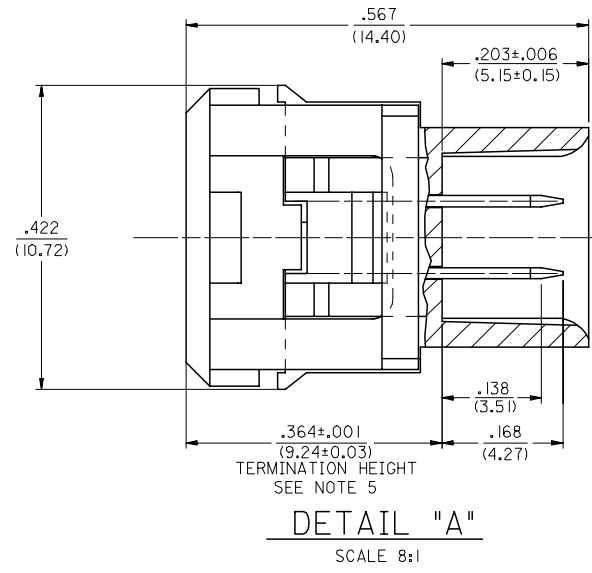
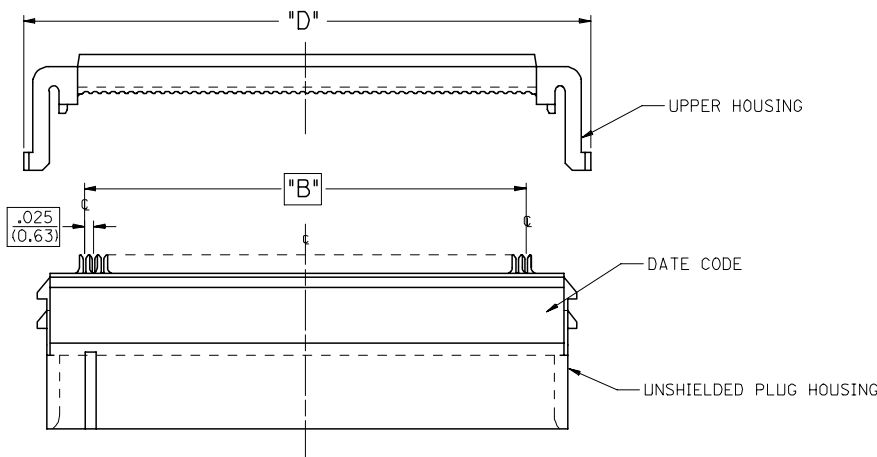

FULLY ASSEMBLED

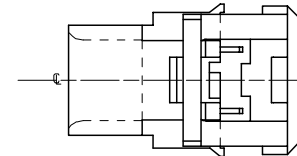

PRE-LOADED

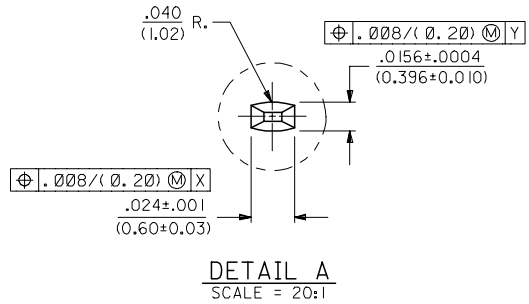

50 CIRCUIT SHOWN

REMOVE OBSOLETE #'S FC NO: UICP2006-2901 DRAWN BY: BARRA 2006/06/12 CHK'D: BARKER 2006/06/12 APPR: SMILLER 2006/06/14	QUALITY SYMBOLS ▽=0 ▽=0	GENERAL TOLERANCES (UNLESS SPECIFIED)		DIMENSION STYLE IN/MM		SCALE 4:1	DESIGN UNITS INCH	THIRD ANGLE PROJECTION	
		mm	INCH	DRAWN BY JLONG	DATE 1993/04/16	TITLE SCSI ALL-PLASTIC MODULAR SUB-ASSEMBLY KIT FOR .025 RIBBON CABLE	MATERIAL NO. SDMS-70498-4***		
4 PLACES ± --- ± ---		3 PLACES ± --- ± .005		CHECKED BY BOWEN		DATE 1993/04/16		SHEET NO. 1 OF 2	
2 PLACES ± 0.13 ± ---		1 PLACE ± --- ± ---		APPROVED BY JD		DATE 1993/04/16		MATERIAL NO. SDMS-70498-4***	
ANGULAR ±1/2°		DRAFT WHERE APPLICABLE MUST REMAIN WITHIN DIMENSIONS		SEE TABLE		DOCUMENT NO. SDMS-70498-4***		SHEET NO. 1 OF 2	
THIS DRAWING CONTAINS INFORMATION THAT IS PROPRIETARY TO MOLEX INCORPORATED AND SHOULD NOT BE USED WITHOUT WRITTEN PERMISSION									

2	J
1	J
SHT	REV

12 11 10 9 8 7 6 5 4 3 2 1

13	12	11	10	9	8	7	6	5	4	3	2	1	TUBE PACKED ITEM NO. (REFER TO) (PK-70873-0271)		TRAY PACKED ITEM NO. (REFER TO) (PK-70873-0302)		CKT. SIZE	PLATING TYPE	ITEM	DESCRIPTION/ITEM NO.	QTY	"A"		"B"		"C"		"D"								
													IN.	MM.	IN.	MM.						IN.	MM.	IN.	MM.											
	NA	NA	40	GOLD 30	A	PLUG ASSEMBLY : 70498-2040	1	.950	24.13	.975	24.77	1.122	28.50	1.372	33.71																					
					B	UPPER HOUSING : 70497-1040	1																													
	NA	NA	50	GOLD 30	A	PLUG ASSEMBLY : 70498-2050	1	1.200	30.48	1.225	31.12	1.372	34.85	1.572	39.93																					
					B	UPPER HOUSING : 70497-1050	1																													
	70498-4068	NA	68	GOLD 30	A	PLUG ASSEMBLY : 70498-2068	1	1.650	41.91	1.675	42.54	1.822	46.28	2.022	51.36																					
					B	UPPER HOUSING : 70497-1068	1																													
	70498-4201	NA	68	GOLD 15	A	PLUG ASSEMBLY : 70498-2168	1	1.650	41.91	1.675	42.54	1.822	46.28	2.022	51.36																					
					B	UPPER HOUSING : 70497-1068	1																													

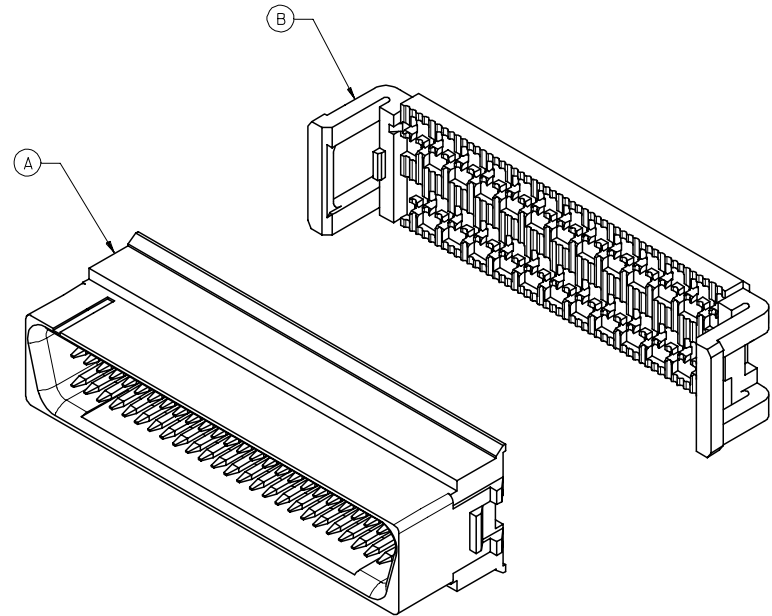
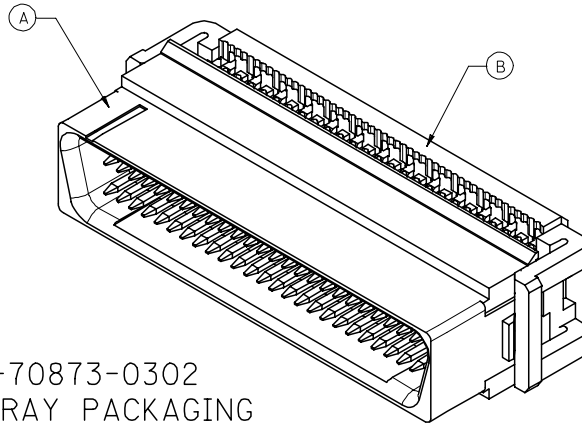

DETAIL FOR PK-70873-0302  
FOR PRE-LOADED TRAY PACKAGING  
ITEM SERIES 70498-41\*\* & -43\*\*

NOTES:

- REFER TO PS-79058 PRODUCT SPEC FOR ELECTRICAL, MECHANICAL AND ENVIRONMENTAL SPECIFICATIONS.
- MATERIAL:  
PLUG HOUSING: POLYESTER (PBT), GLASS FILLED, UL94 V-0, COLOR: BLACK.  
CONTACT: PHOSPHOR BRONZE  
UPPER HOUSING: POLYESTER (PBT), GLASS FILLED, UL94 V-0, COLOR: BLACK.

FINISHES: TERMINALS:

(GOLD 15)  
SELECTIVE GOLD: THICKNESS= 15 MICROINCHES/(0.38 MICROMETERS) MINIMUM.  
SELECTIVE TIN: THICKNESS= 75 MICROINCHES/(1.90 MICROMETERS) MINIMUM.  
NICKEL UNDERPLATE OVERALL.

(GOLD 30)  
SELECTIVE GOLD: THICKNESS= 30 MICROINCHES/(0.76 MICROMETERS) MINIMUM.  
SELECTIVE TIN: THICKNESS= 75 MICROINCHES/(1.90 MICROMETERS) MINIMUM.  
NICKEL UNDERPLATE OVERALL.

3. PACKAGING:

- \* - PK-70873-0271 PLUG SUBASSEMBLY SUPPLIED IN TUBES AND UPPER HOUSING SUPPLIED IN BULK.
- \* - PK-70873-0302 IS A PRODUCT OF PK-70873-0271, BUT THE UPPER HOUSING ARE PRE-LOADED ONTO THE PLUG ASSEMBLIES THEN PLACED INTO TRAYS FOR SHIPMENT TO CUSTOMER.

4. RECOMMENDED CABLE: 30 AWG STRANDED OR SOLID, .025 RIBBON. CONTACT MOLEX INC. FOR LIST OF APPROVED CABLES.

5. APPLICATION TOOL CLOSURE OVER ASSY TO BE CONTROLLED TO .364±.001 USING A POSITIVE STOP TO ASSURE PROPER TERMINATION.

NOTE FOR LEAD FREE CONVERSION:

THE PRIMARY SHIPPING CARTON WILL BE LABELED "COMPLIANT TO RoHS DIRECTIVE 2002/95/EC AND ELV ANNEX II OF DIRECTIVE 2000/53/EC". CARTONS WITHOUT THIS LABEL MAY CONTAIN PRODUCT WITH LEAD.

DETAIL FOR PK-70873-0271  
FOR TUBE / BULK PACKAGING  
ITEM SERIES 70498-40\*\* & -42\*\*

REMOVE OBSOLETE #S FC NO: UCP2006-2901 DRAWN BY: BARRA 2006/06/12 CHKD BY: BARKER 2006/06/12 APPR: SMILLER 2006/06/14	DESCRIPTION REV	QUALITY SYMBOLS =0 =0	GENERAL TOLERANCES (UNLESS SPECIFIED)		DIMENSION STYLE IN/MM		SCALE 4:1	DESIGN UNITS INCH	THIRD ANGLE PROJECTION	
			mm	INCH	DRAWN BY JLONG	DATE 1993/04/16	TITLE SCSI ALL-PLASTIC MODULAR SUB-ASSEMBLY KIT FOR .025 RIBBON CABLE			
			4 PLACES ± --- ± ---	3 PLACES ± --- ± ---	CHECKED BY BOWEN	DATE 1993/04/16	MATERIAL NO. SDMS-70498-4***			
			2 PLACES ± --- ± ---	1 PLACE ± --- ± ---	APPROVED BY JD	DATE 1993/04/16	SHEET NO. 2 OF 2			
		ANGULAR ±1/2°		DRAFT WHERE APPLICABLE MUST REMAIN WITHIN DIMENSIONS		SEE TABLE		THIS DRAWING CONTAINS INFORMATION THAT IS PROPRIETARY TO MOLEX INCORPORATED AND SHOULD NOT BE USED WITHOUT WRITTEN PERMISSION		