

|             |                                     |      |      |
|-------------|-------------------------------------|------|------|
| PART NUMBER | SML-LXR851SGC-TR                    | REV. | B    |
| DATE        | E.C.N. NUMBER AND REVISION COMMENTS |      | REV. |
| 09.07.04    | E.C.N. #10967.                      |      | A    |
| 05.16.11    | E.C.N. #11710/10BRDR. & REDRAWN.    |      | B    |

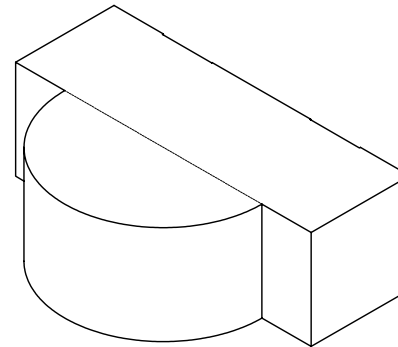
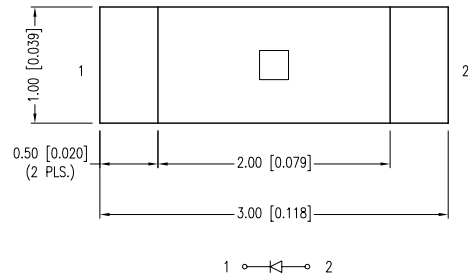

ELECTRO-OPTICAL CHARACTERISTICS TA =25°C If=20mA

| PARAMETER          | MIN         | TYP. | MAX | UNITS    | TEST COND |
|--------------------|-------------|------|-----|----------|-----------|
| PEAK WAVELENGTH    |             | 565  |     | nm       |           |
| FORWARD VOLTAGE    |             | 2.1  | 2.4 | Vf       |           |
| REVERSE VOLTAGE    | 5.0         |      |     | Vr       | If=100µA  |
| AXIAL INTENSITY    |             | 16   |     | mcd      | If=20mA   |
| VIEWING ANGLE      |             | 120  |     | 2x theta |           |
| EMITTED COLOR:     | GREEN       |      |     |          |           |
| EPOXY LENS FINISH: | WATER CLEAR |      |     |          |           |

LIMITS OF SAFE OPERATION AT 25°C

| PARAMETER             | MAX        | UNITS |
|-----------------------|------------|-------|
| PEAK FORWARD CURRENT* | 160        | mA    |
| STEADY CURRENT        | 25         | mA    |
| POWER DISSIPATION     | 100        | mW    |
| DERATE FROM 25°C      | -1.2       | mW/°C |
| OPERATING TEMP.       | -25 TO +85 | °C    |
| STORAGE TEMP.         | -30 TO +85 | °C    |

\* t<10µs

**CAUTION: MOISTURE SENSITIVE DEVICE**  
PER JEDEC LEVEL 2 STANDARDS

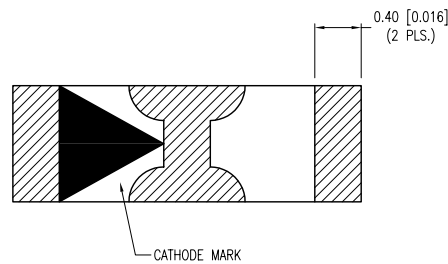
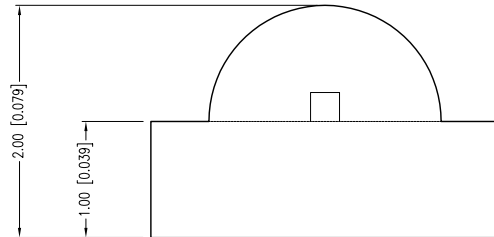

RECOMMENDED SOLDER PAD LAYOUT

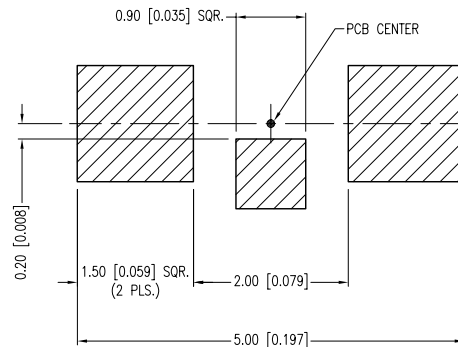

\*UNLESS OTHERWISE SPECIFIED TOLERANCES PER DECIMAL PRECISION ARE: X=±1 (±0.039), X.X=±0.5 (±0.020), X.XX=±0.25 (±0.010), X.XXX=±0.127 (±0.005). LEAD SIZE=±0.05 (±0.002), LEAD LENGTH=±0.75 (±0.030). MIN= +DECIMAL PRECISION MAX.= +0.00 -DECIMAL PRECISION

**LUMEX**  
Creating LED and LCD Solutions Together™

290 E. HELEN ROAD  
PALATINE, IL 60067-6976  
PHONE: +1.847.359.2790  
FAX: +1.847.359.6538  
WEB: WWW.LUMEX.COM

1.0x3.0mm PCB RIGHT ANGLE SURFACE MOUNT LED, 565nm GREEN, WATER CLEAR LENS, TAPE & REEL.

\*\*THE SPECIFICATIONS MAY CHANGE AT ANY TIME WITHOUT NOTICE DUE TO NEW MATERIALS OR PRODUCT IMPROVEMENT.\*\*

CONFIDENTIAL INFORMATION  
THE INFORMATION CONTAINED IN THIS DOCUMENT IS THE PROPERTY OF LUMEX INC. EXCEPT AS SPECIFICALLY AUTHORIZED IN WRITING BY LUMEX INC., THE HOLDER OF THIS DOCUMENT SHALL KEEP ALL INFORMATION CONTAINED HEREIN CONFIDENTIAL AND SHALL PROTECT SAME IN WHOLE OR IN PART FROM DISCLOSURE AND DISSEMINATION TO ALL THIRD PARTIES.

UNCONTROLLED DOCUMENT

|        |           |           |    |
|--------|-----------|-----------|----|
| DATE:  | 05.16.11  | DRAWN BY: | AB |
| PAGE:  | 1 OF 2    | CHKD BY:  | KF |
| SCALE: | NTS       | APRVD BY: | SS |
| UNIT:  | mm [INCH] |           |    |

|             |                                     |      |      |
|-------------|-------------------------------------|------|------|
| PART NUMBER | SML-LXR851SGC-TR                    | REV. | B    |
| DATE        | E.C.N. NUMBER AND REVISION COMMENTS |      | REV. |
| 09.07.04    | E.C.N. #10967.                      |      | A    |
| 05.16.11    | E.C.N. #11710/10BRDR. & REDRAWN.    |      | B    |

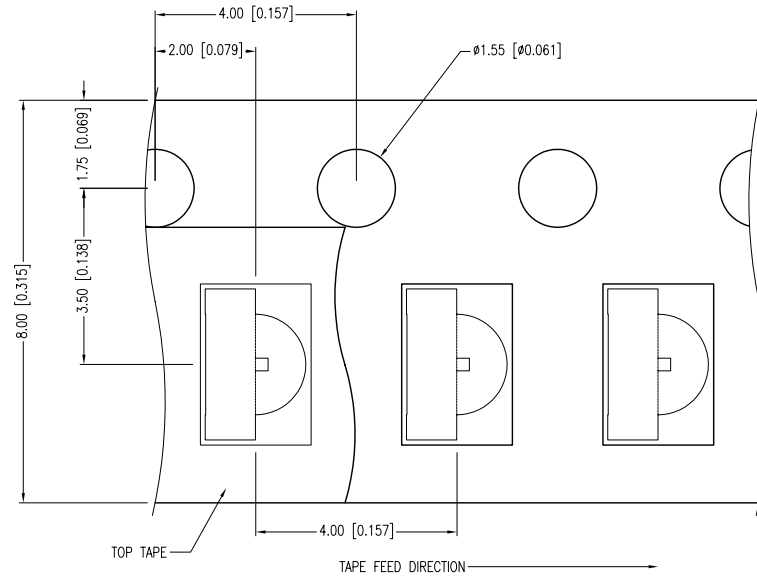
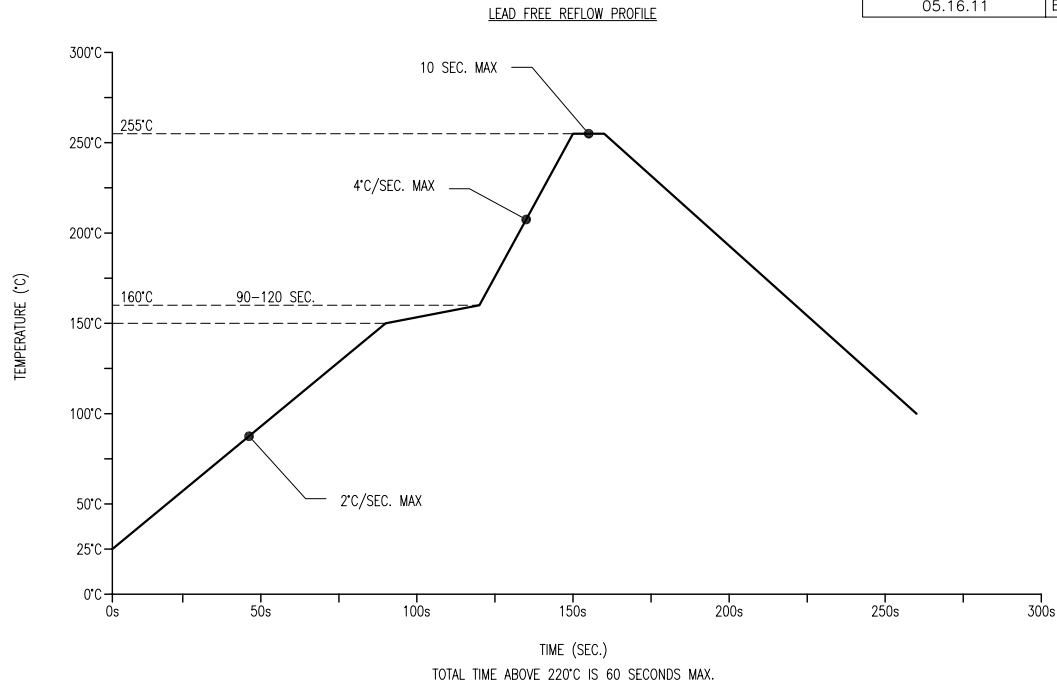

- NOTES:**
- 2,000 PER REEL.
  - THE CATHODE IS ORIENTED TOWARDS THE TAPE SPROCKET HOLE.

\*UNLESS OTHERWISE SPECIFIED TOLERANCES PER DECIMAL PRECISION ARE: X=±1 (±0.039), X.X=±0.5 (±0.020), X.XX=±0.25 (±0.010), X.XXX=±0.127 (±0.005). LEAD SIZE=±0.05 (±0.002), LEAD LENGTH=±0.75 (±0.030). MIN= <sup>+DECIMAL PRECISION</sup> -0.00 MAX= <sup>+DECIMAL PRECISION</sup> -0.00



290 E. HELEN ROAD  
PALATINE, IL 60067-6976  
PHONE: +1.847.359.2790  
FAX: +1.847.359.6538  
WEB: WWW.LUMEX.COM

1.0x3.0mm PCB RIGHT ANGLE SURFACE MOUNT LED, 565nm GREEN, WATER CLEAR LENS, TAPE & REEL.

\*\*THE SPECIFICATIONS MAY CHANGE AT ANY TIME WITHOUT NOTICE DUE TO NEW MATERIALS OR PRODUCT IMPROVEMENT.\*\*

CONFIDENTIAL INFORMATION  
THE INFORMATION CONTAINED IN THIS DOCUMENT IS THE PROPERTY OF LUMEX INC. EXCEPT AS SPECIFICALLY AUTHORIZED IN WRITING BY LUMEX INC., THE HOLDER OF THIS DOCUMENT SHALL KEEP ALL INFORMATION CONTAINED HEREIN CONFIDENTIAL AND SHALL PROTECT SAME IN WHOLE OR IN PART FROM DISCLOSURE AND DISSEMINATION TO ALL THIRD PARTIES.

|        |           |           |    |
|--------|-----------|-----------|----|
| DATE:  | 05.16.11  | DRAWN BY: | AB |
| PAGE:  | 2 OF 2    | CHKD BY:  | KF |
| SCALE: | NTS       | APRVD BY: | SS |
| UNIT:  | mm [INCH] |           | Ⓟ  |