

PART NUMBER	REV	FIRST USED	POWER UNIT	FEED TYPE
567228-1	G	-	LEADMAKER	AIR FEED
567228-2	G	-	AMP-O-LECTRIC	AIR FEED

- 1 RECOMMENDED SPARE PARTS.
- 2 GREASE LIGHTLY
- 3 GUARD MUST BE IN PLACE WHEN OPERATING APPLICATOR IN AMP-O-LECTRIC MACHINE.
- 4 SEE DRAWING FOR COMPONENTS
- 5 TO CHECK CRIMP HEIGHT, CRIMP SOLDER (3/16 DIA 60/40 SOLID CORE) AND MEASURE AT CENTER OF SLUG.

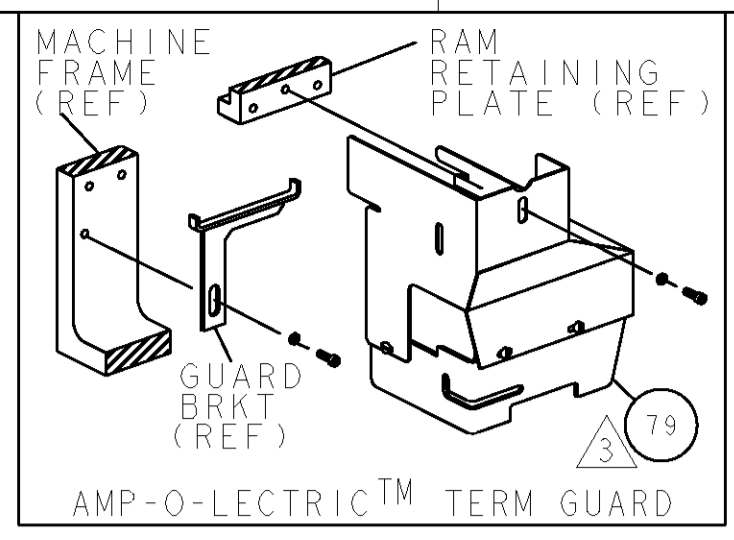

TERMINAL NAME: ULTRA-FAST FLAG .250					
520856	-	TE TERMINAL - TE CRIMP SPECS			
-	-	PAD LTR	CRIMP HEIGHT	WIRE SIZE	SOLDER DIA
-	-	A	.070±.002 [1.78±0.05mm]	22 OR 20	∅.19
-	-	B	.065±.002 [1.65±0.05mm]	-	∅.19
-	-	C	-	-	-
-	-	D	-	-	-
-	-	CRIMP WIRE	SIZE	TYPE	RANGE
-	-	-	.201 [5.10mm]	D	18 - 22
-	-	INSUL	-	-	.230 [5.84mm] MAX
WIRE STRIP LENGTH	TERM APPL SPEC	FEED	APPLICATOR INSTRUCTIONS	SET UP GAGE	
-	114-2123	.740 [18.80mm]	A18058	458638-2	

LOC	REV	DESCRIPTION	DATE	BY	APPV
A	66				
G		ECR-07-003348	12FEB2007	BW	TM
G1		ECR-08-29783	10DEC2008	DM	GB

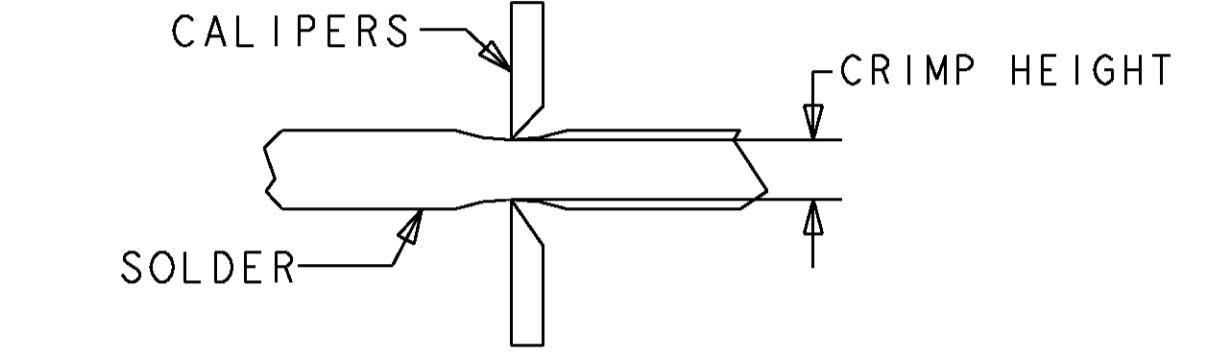

- 6 CUT TO LENGTH AT ASSEMBLY.
- ALLOWABLE WIRE SIZES:  
18 AWG OR  
(2)22 AWG OR  
(1)20 AWG+(1)22 AWG

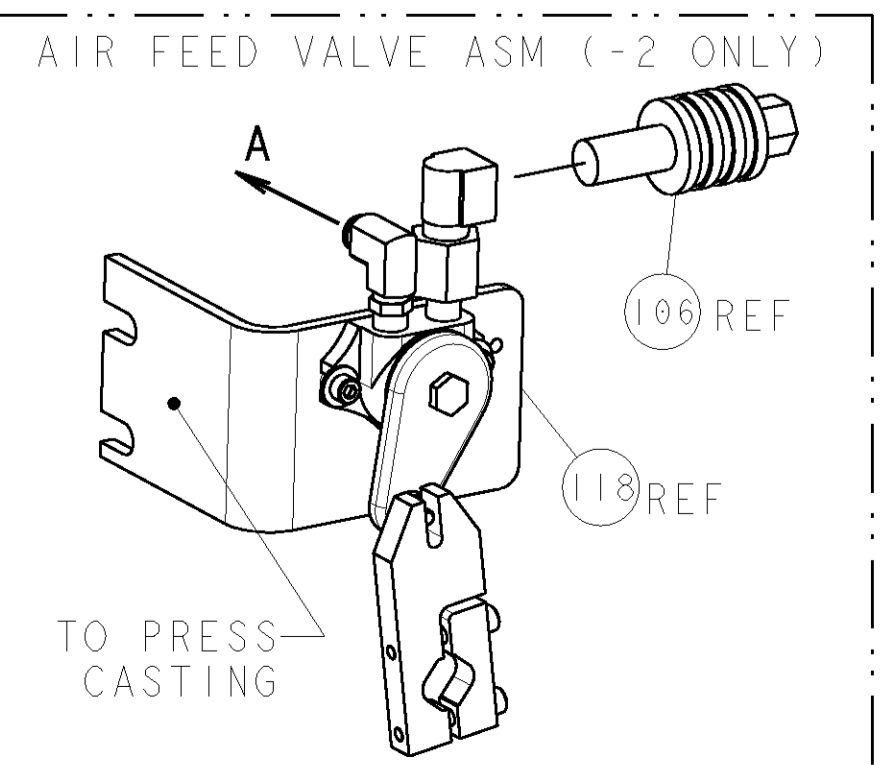
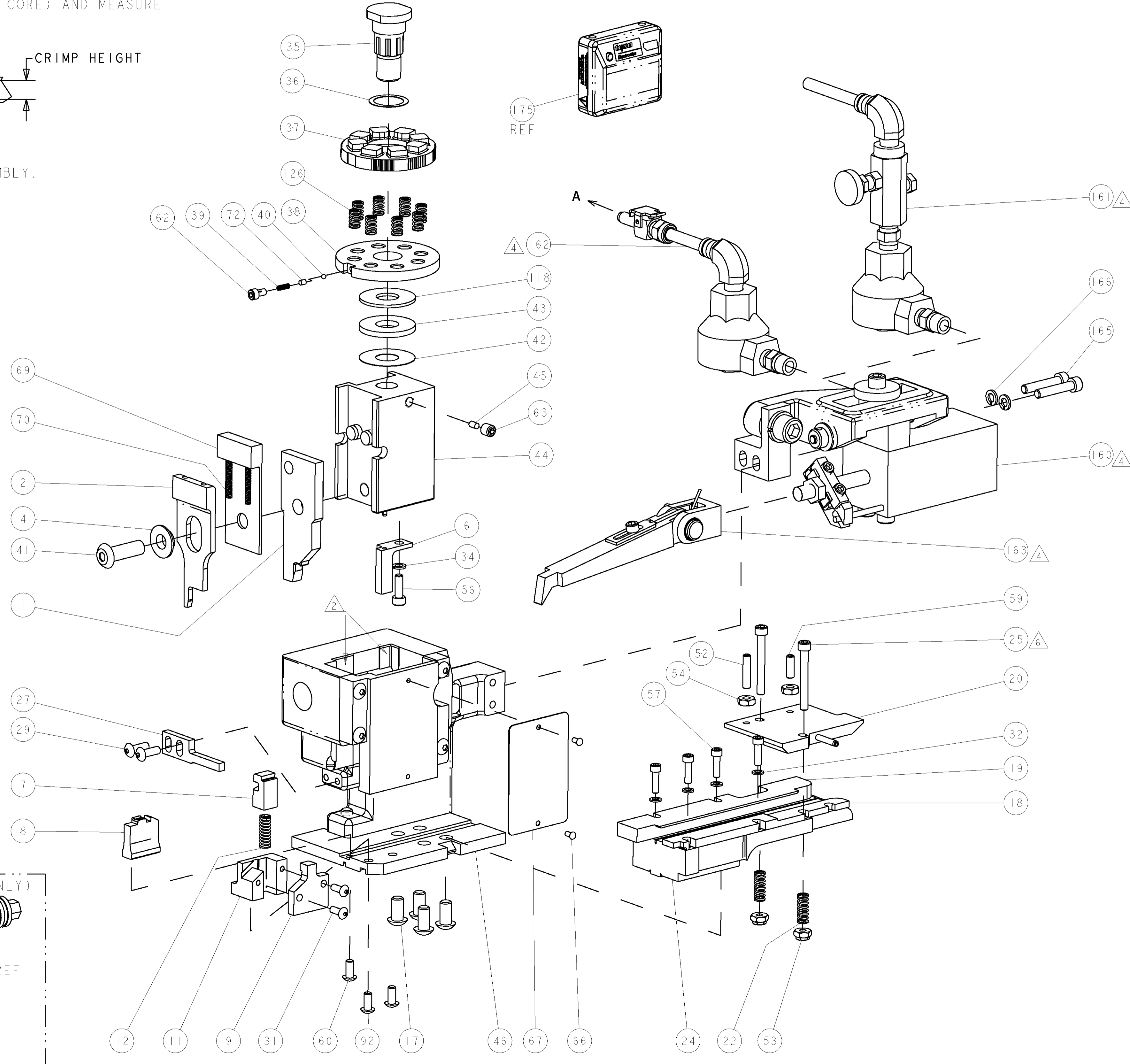

REF	REF	QTY	DESCRIPTION	ITEM NO
4	REF	-	1804300-1 ASSEMBLY, APPLICATOR COUNTER	175
2	2	-	692655-6 AIR FEED VALVE ASSEMBLY	173
2	2	-	21024-5 WASHER, SPRG LOCK, REG NO 10	166
2	2	-	3-21000-9 SCR, SKT HD CAP 10-32 X 1.000	165
4	1	-	1-460680-2 FEED FINGER ASSEMBLY	163
4	1	-	692655-7 AIR FEED VALVE ASSEMBLY	162
4	1	-	692655-5 AIR FEED VALVE ASSEMBLY	161
1	1	-	460277-3 AIR FEED ASSY	160
8	8	-	2-22280-5 SPRING, COMPRESSION	126
1	1	-	690124-5 WASHER, RAM (.062)	118
REF	-	-	24042-2 VALVE, SHUT-OFF	106
2	2	-	2-21002-1 SCR, BTN SKT HD CAP 8-32 X .375	92
1	1	-	690603-1 SPRING ASSIST AMP-O-MATOR APPLICATOR	72
2	2	-	5-22278-1 SPRING, COMPRESSION	70
1	1	-	462842-1 SPACER	69
1	1	-	461264-1 PLATE, IDENTIFICATION	67
2	2	-	21017-2 SCREW, DRIVE	66
1	1	-	21009-2 SCR, SET, SELF LOCKING 1/4-20 X .250	63
1	1	-	23030-1 SCR, SKT HD CAP, S-LOCK, 6-32 X .25	62
1	1	-	22733-8 SCR, BHSC, SELF-LOCKING, 8-32 X .375	60
1	1	-	4-21006-4 SCR, SET, CUP POINT 8-32 X .500	59
4	4	-	2-21000-0 SCR, SKT HD CAP 6-32 X .500	57
1	1	-	2-21000-7 SCR, SKT HD CAP 8-32 X .500	56
2	2	-	21018-6 NUT, HEX, REG 8-32	54
2	2	-	21022-2 NUT, HEX, SELF-LOCKING, THIN, 8-32	53
1	1	-	4-21010-6 SET SCREW, SOCKET HD, FLAT POINT	52
1	1	-	816186-1 BASIC APPLICATOR SUB ASS'Y	46
1	1	-	690191-1 PLUG, NYLON	45
1	1	-	683741-1 RAM	44
1	1	-	690124-1 WASHER, RAM (.115)	43
1	1	-	690125-1 SHIM SUB-ASSY	42
1	1	-	690686-2 CRIMPER, BOLT SPECIAL	41
1	1	-	23241-6 BALL, STEEL	40
1	1	-	690170-1 SPRING, COMPRESSION	39
1	1	-	462426-1 DISC, SPRING	38
1	1	-	462425-1 WIRE DISC	37
1	1	-	22480-5 WASHER, WAVE SPRING	36
1	1	-	690212-1 POST, RAM	35
1	1	-	21024-4 WASHER, SPRG LOCK, REG NO 8	34
4	4	-	21024-3 WASHER, SPRG LOCK, REG NO 6	32
2	2	-	1-21002-7 SCR, BTN SKT HD CAP 6-32 X .375	31
2	2	-	2-21002-2 SCR, BTN SKT HD CAP 8-32 X .500	29
1	1	-	690455-3 STRIPPER, FRONT CASTING	27
2	2	-	8-21909-7 SCR, SKT HD CAP 8-32 X 1.375	25
1	1	-	467285-4 PLATE, GUIDE, STRIP	24
2	2	-	2-22280-9 SPRING, COMPRESSION	22
1	1	-	467283-1 DRAG	20
1	1	-	683736-2 GUIDE, STRIP, REAR	19
1	1	-	683737-1 FRONT STRIP GUIDE	18
4	4	-	3-21002-3 SCR, BTN SKT HD CAP 1/4-20 X .500	17
1	1	-	4-22280-7 SPRING, COMPRESSION	12
1	1	-	467501-1 HOLDER, SHEAR, FLOATING	11
1	1	-	467281-1 RETAINER, SHEAR, FLOATING	9
1	1	-	467341-3 ANVIL, RIGHT HAND	8
1	1	-	467500-1 SHEAR, FLOATING	7
1	1	-	467499-2 SHEAR DEPRESSOR	6
1	1	-	238009-1 BLOCK, FL CRIMPER SPACER	4
1	1	-	467282-4 STABILIZER	2
1	1	-	467342-1 CRIMPER, RIGHT HAND	1

DIMENSIONS: IN 		TOLERANCES UNLESS OTHERWISE SPECIFIED: 9 PLC ±.005 1 PLC ±.002 5 PLC ±.001 4 PLC ±.0005 ANGLES ±.005		DWG: B. WEAVER 29JAN2007 CHK: T. ELBIN 29JAN2007 APVD: T. ELBIN 29JAN2007		<b>tyco</b> Tyco Electronics Harrisburg, PA 17105-3608	
MATERIAL: -		FINISH: -		WEIGHT: -		SCALE: 3:4	
CUSTOMER DRAWING		PART NO: A100779		DESCRIPTION: END FEED HDM APPLICATOR		SHEET 1 OF 1	

CUSTOMER VIEWABLE ASSEMBLY