

NUMBER 41278

© 1966 BY AMP INCORPORATED. ALL RIGHTS RESERVED. AMP PRODUCTS COVERED BY PATENTS AND/OR PATENTS PENDING. APPROVED PER GOVT CONTRACT NO.

REVISIONS				
SYM	ZONE	DESCRIPTION	DATE	APPROVAL
V		REVISED & REDRAWN	7-981	8/7/63
W		REVISED	V-96	6-16-64
Y		REVISED	1385	5-19-67
Z		OBSOLETE 41938, 41862 (2162) 2959	4-2-70	M.S. D.H.
AA		OBSOLETE 41496 PER ECN 3343	2-4-72	J.W. D.H.
AB		PRINT DIST. 12 WAS 39: LOC 5 WAS AB: ECN 7275	9/18/72	C.T.L.
AC		HAND TOOL 48698 WAS 90000	5-9-73	R.C.H.
AD	CS	REACTIVATED 41496	ECN 49	7-8-75
AE		OBSOLETE 41646-2 & 41663-2	EA 1049	12-29-78
AF		REVISED PLATING	EA 1515	7-29-80
AG		BRIGHT TIN-LEAD WAS BRIGHT TIN	EA 1818	6-16-81
AH		REVISED GOLD PLATING	EA 2139	6-15-82
AJ		085 42526-1 & -2, 42600-2	ECN 53379	11-19-86

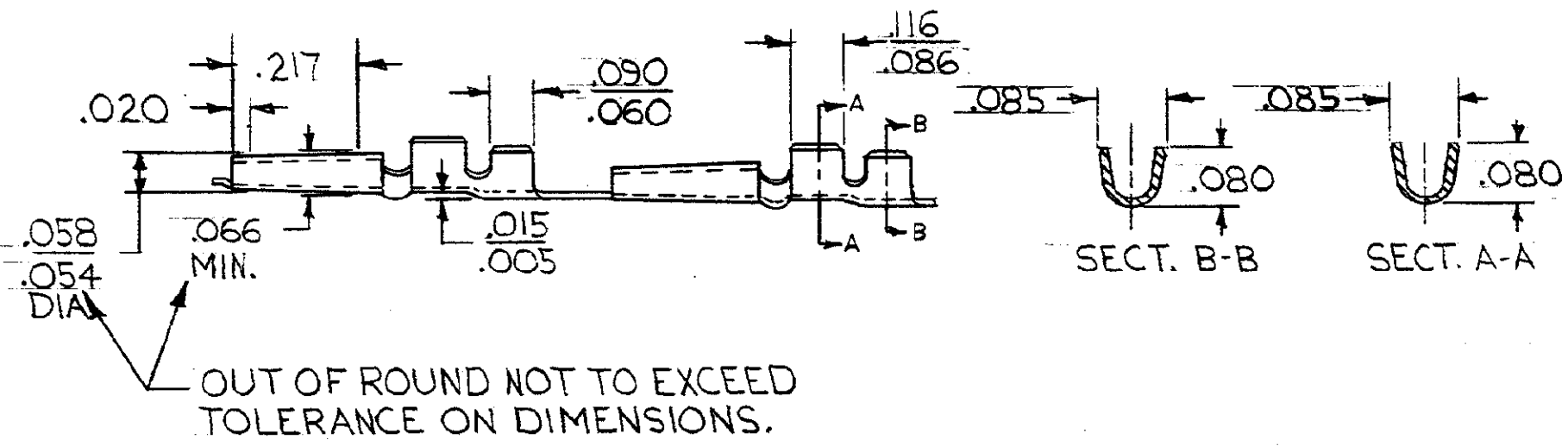
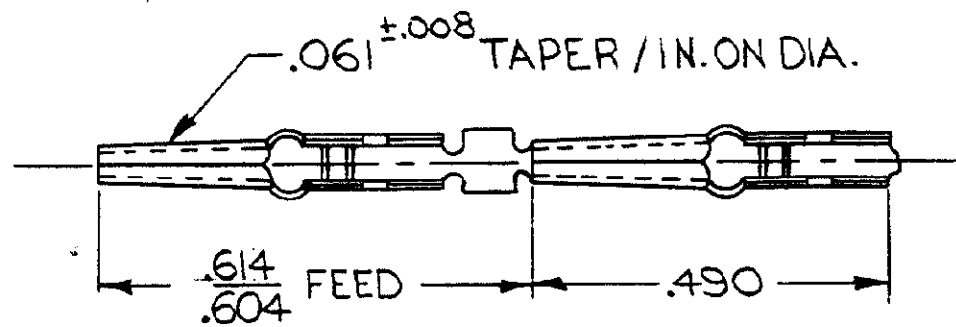

OUT OF ROUND NOT TO EXCEED TOLERANCE ON DIMENSIONS.

STRIP

⚠ OBSOLETE PART NO.

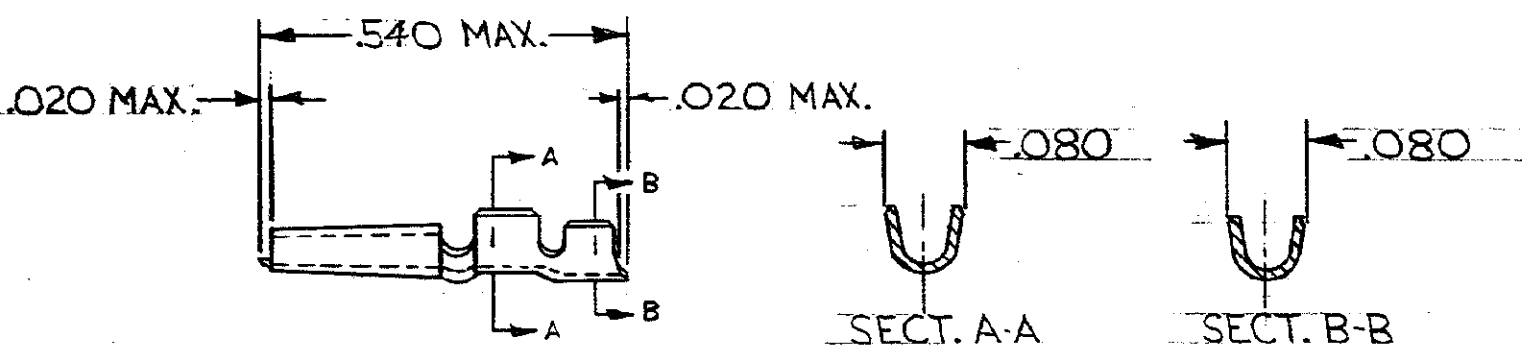

LOOSE PIECE

OBSOLETE	41646-2	41663-2	24-22	.040-.055	.000020 GOLD OVER .000050 NICKEL	380306-2	48698	.034
	41496	42526-1	↑	.040-.055	PLAIN	380306-2	48698	.034
OBSOLETE	42600-2	42526-2			.0002 GOLD OVER .00005 NICKEL			
	42600-1	42526-3			.00005 GOLD OVER .00005 NICKEL			
OBSOLETE	41862	41938			.0001 GOLD OVER .0001 SILVER			
	41646	41663			.00003 GOLD OVER .00005 NICKEL			
	41640	41662			.0002 SILVER			
	41278	41661	24-22	.040-.055	.0001 BRIGHT TIN-LEAD	380306-2	48698	.034
STRIP NO.	L.P. NO.	WIRE SIZE	INSUL SIZE	FINISH		INSERT TOOL	HAND TOOL	C.H.

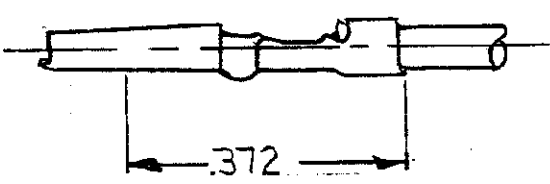
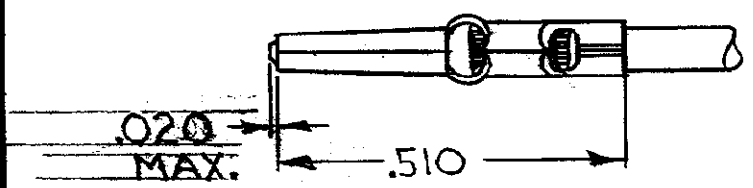

MAX. INSTALLED EXTENSION

CRIMPED VERSION

AMP INFO		QTY REQD	NOMENCLATURE OR DESCRIPTION	PART OR IDENTIFYING NO
M	3	5/2		
LIST OF MATERIALS OR PARTS LIST				
UNLESS OTHERWISE SPECIFIED DIMENSIONS ARE IN INCHES TOLERANCES ON FRACTIONS DECIMALS ANGLES ± .# ± .010 ± .#			SIGNATURE	DATE
MATERIAL			DR	
HEAT TREAT			CHK	
			DSGN ENGR	
			APPR	
			DSGN APPR	
			AMP INCORPORATED HARRISBURG, PENNSYLVANIA	
			PIN, TAPER, 53 SERIES	
CODE IDENT. NO		SIZE	NUMBER	
00779		C	41278	
CALC		ACTUAL	SHEET	

CUSTOMER DRAWING